



PRECAST CONCRETE PRODUCTS

2022 CATALOGUE

M CON
P R O D U C T S

2150 Richardson Side Road
Ottawa, ON, K0A 1L0, Canada
t. +1 800 267 5515
e. sales@mconproducts.com

www.mconproducts.com



M CON Products
2150 Richardson Side Road
Ottawa, ON, K0A 1L0, Canada
t. + 1 800 267 5515
e. sales@mconproducts.com

TABLE OF CONTENTS

- SECTION 1 CONCRETE PIPE.3
- SECTION 2 BOX CULVERTS.19
- SECTION 3 MAINTENANCE HOLES33
- SECTION 4 STORMWATER RETENTION SYSTEM78
- SECTION 5 OGS UNITS81
- SECTION 6 CATCH BASINS.83
- SECTION 7 HEADWALLS93
- SECTION 8 TRENCH COVERS.99
- SECTION 9 STONE STRONG SYSTEMS®.101
- SECTION 10 ACCESSORIES112



SECTION 1

CONCRETE PIPE

M CON
PRODUCTS



M CON Products
 2150 Richardson Side Road
 Ottawa, ON, K0A 1L0, Canada
 tf. + 1 800 267 5515
 e. sales@mconproducts.com

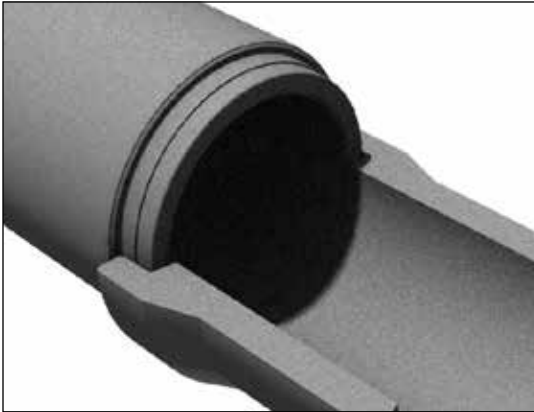
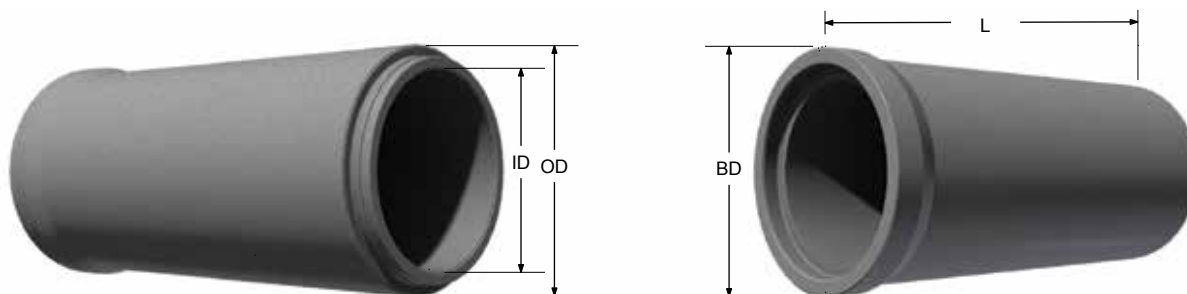

TABLE OF CONTENTS

SECTION 1 CONCRETE PIPE	3
Mass and Dimension 300-900mm Pipe	5
Mass and Dimension 975-3600mm Pipe	6
Mass and Dimension Elliptical Pipe	7
Jacking Pipe	8
45° and 90° Bend Dimension	9
Tee and Wye Dimensions	10
3 Stage Cored Tee (for PVC pipe applications)	11
PVC Adapter Tee 300-600mm	12
Concrete Pipe Plugs and Caps	13
Concrete Pipe Reducers and Increases	14
Pipe Maintenance Hole Tees	15
Pipe Joint Detail 300-750mm	16
Pipe Joint Detail 825-3600mm	17
Joint Procedure - Pre-Lubricated Gaskets	18





Designated Internal Diameter (Nominal)	Actual Diameter (ID)	Outside Diameter (OD)	Wall Thickness (W)	Bell Diameter (BD)	Lay Length (L)	Waterway Area	Approximate Mass	Truckload Lots
mm	mm	mm	mm	mm	m	m ²	kg/pc	pcs
300	305	445	70	498	2.29	0.07	486	65
375	381	533	76	587	2.29	0.11	648	50
450	457	622	83	702	2.44	0.16	878	40
525	533	711	89	752	2.29	0.22	1016	34
600	610	800	95	829	2.29	0.29	1232	28
675	686	889	102	905	2.29	0.37	1458	22
750	762	978	108	1003	2.29	0.46	1716	19
825	838	1067	114	-	2.29	0.55	1874	18
900	914	1156	121	-	2.29	0.66	2253	17

Mass and Dimension 300-900mm Pipe

Notes

1. Manufactured in accordance with CSA-A257.2.
2. All standard reinforced concrete pipe classes available: 50-D, 65-D, 100-D and 140-D.
3. Contact our engineering department for special design concrete pipe applications.
4. All pipe joints come complete with pre-lubricated rubber gaskets.



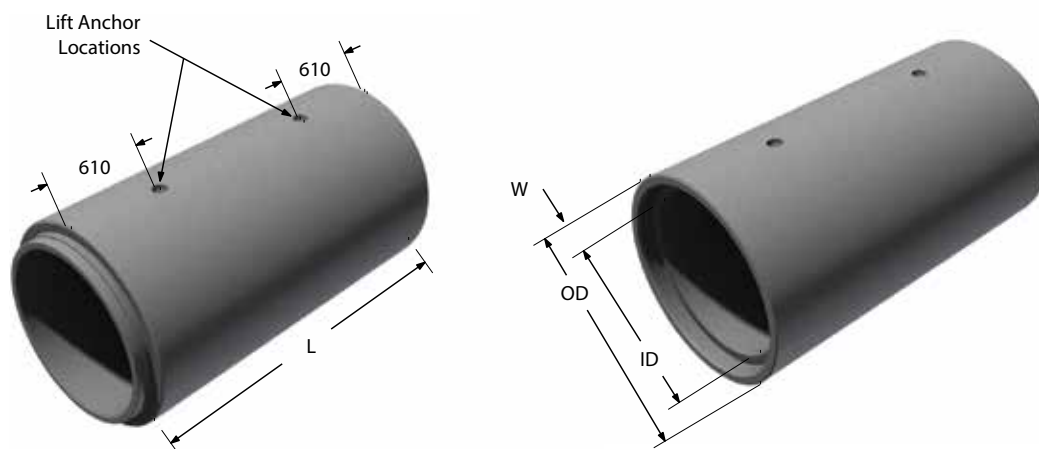

Designated Internal Diameter (Nominal)	Actual Diameter (ID)	Outside Diameter (OD)	Wall Thickness (W)	Lay Length (W)	Waterway Area	Approximate Mass	Lift Anchor Size	Truckload Lots
mm	mm	mm	mm	m	m ²	kg/pc	ton	pcs
975	991	1245	127	2.29	0.77	2567	4	12
1050	1067	1334	133	2.29	0.89	2919	4	11
1200	1220	1511	146	2.29	1.17	3661	4	9
1350	1372	1689	159	2.29	1.48	4429	4	8
1500	1524	1867	171	2.44	1.82	5734	4	6
1650	1676	2045	184	2.44	2.21	6719	4	5
1800	1829	2223	197	2.44	2.63	7846	8	4
1950	1981	2362	190	2.44	3.08	8390	8	4
2100	2134	2540	203	2.44	3.58	9562	8	4
2250	2286	2717	215	2.44	4.10	10726	8	3
2400	2438	2896	229	2.44	4.67	12214	8	2
2550	2591	3073	241	2.44	5.27	13776	8	2
2700	2743	3251	254	2.44	5.91	15139	8	2
3000	3048	3606	279	2.44	7.30	18786	20	1
3600	3656	4356	349	2.44	10.51	26340	20	1

Mass and Dimension 975-3600mm Pipe

Notes

1. Manufactured in accordance with CSA-A257.2.
2. All standard reinforced concrete pipe classes available: 50-D, 65-D, 100-D and 140-D.
3. Contact our engineering department for special design concrete pipe applications.
4. All pipe joints come complete with pre-lubricated rubber gaskets.



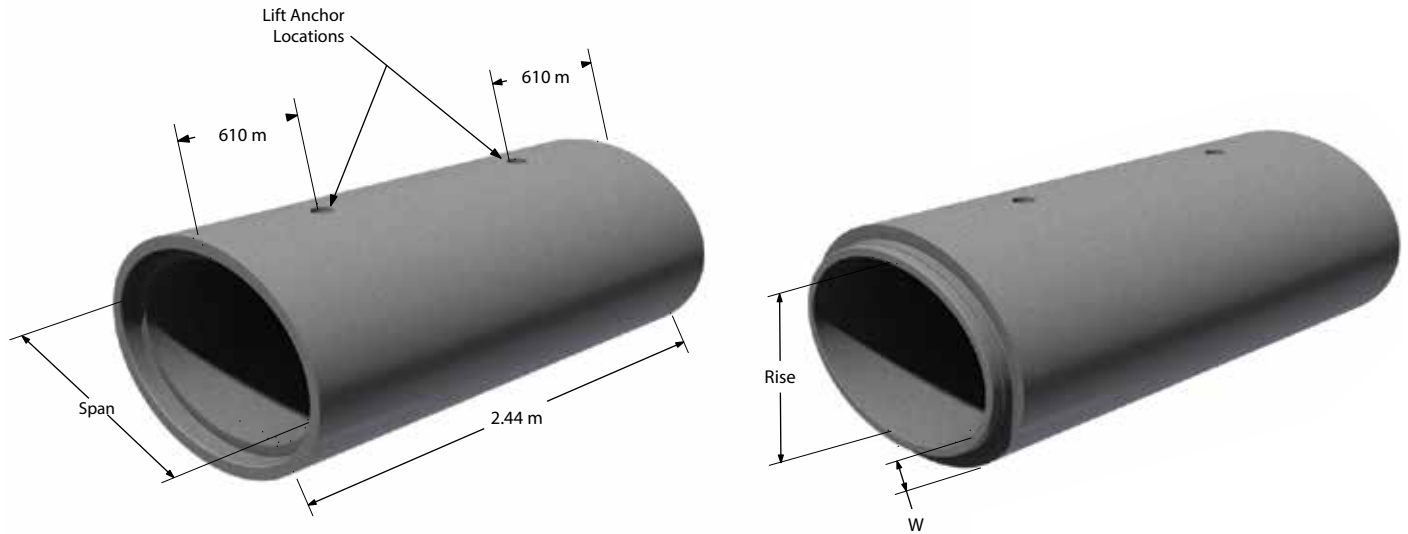

Designated Size Rise X Span	Designated Equivalent Circular Pipe Diameter	Actual Size Rise X Span	Wall Thickness (W)	Waterway Area	Approximate Mass	Truckload Lots
mm	mm	mm	mm	m ²	kg/pc	pcs
480 x 760	600	483 x 762	83	0.29	1252	38
610 x 965	750	610 x 965	95	0.46	1583	20
730 x 1150	900	737 x 1143	114	0.69	2283	11
855 x 1345	1050	864 x 1346	127	0.95	2928	8
975 x 1535	1200	965 x 1524	140	1.20	3665	6
1090 x 1730	1350	1092 x 1727	152	1.54	4518	6
1220 x 1920	1500	1219 x 1930	165	1.91	5421	5
1340 x 2110	1650	1346 x 2108	178	2.30	6401	4
1465 x 2305	1800	1473 x 2311	191	2.74	7464	4
1585 x 2495	1950	1600 x 2489	203	3.22	8622	3
1705 x 2690	2100	1727 x 2692	216	3.73	9845	3
1825 x 2870	2250	1829 x 2870	229	4.12	11151	2
1950 x 3070	2400	1956 x 3073	241	4.87	12535	2
2080 x 3250	2550	2083 x 3251	247	5.31	13518	2
2195 x 3455	2700	2210 x 3454	267	6.17	15597	1

Mass and Dimension Elliptical Pipe

Notes

1. Manufactured in accordance with ASTM C 507.
2. Standard reinforced concrete HE pipe classes available: HE-I, HE-II, HE-III, HE-IV.
3. All pipe joints come complete with butyl gasket.





M CON
PRODUCTS

M CON Products

2150 Richardson Side Road
Ottawa, ON, K0A 1L0, Canada

tf. + 1 800 267 5515

e. sales@mconproducts.com

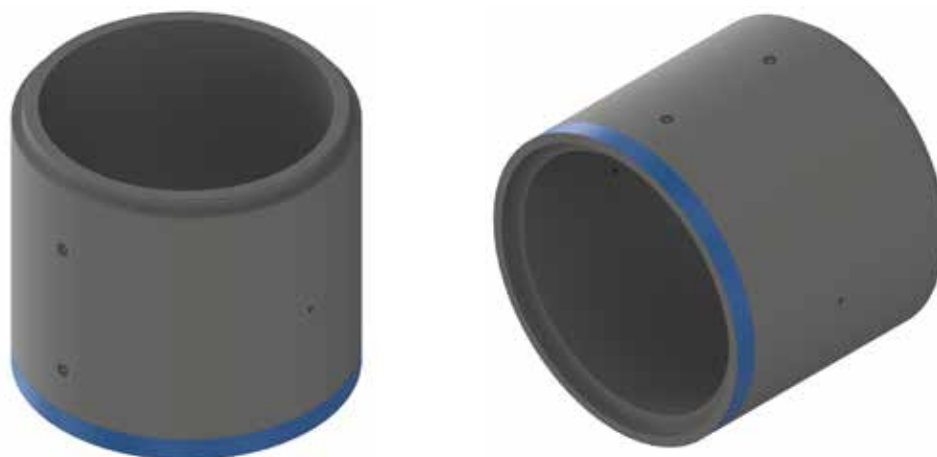

Inside Dimensions

mm
825
900
975
1050
1200
1350
1500
1650
1800
1950
2100
2250
2400
2550
2700
3000

Jacking Pipe

Notes

1. Available in 100-D and 140-D.
2. Manufactured in accordance with ASTM C 507.
3. Standard reinforced concrete HE pipe classes available: HE-I, HE-II, HE-III, HE-IV.
4. All pipe joints come complete with butyl gasket.



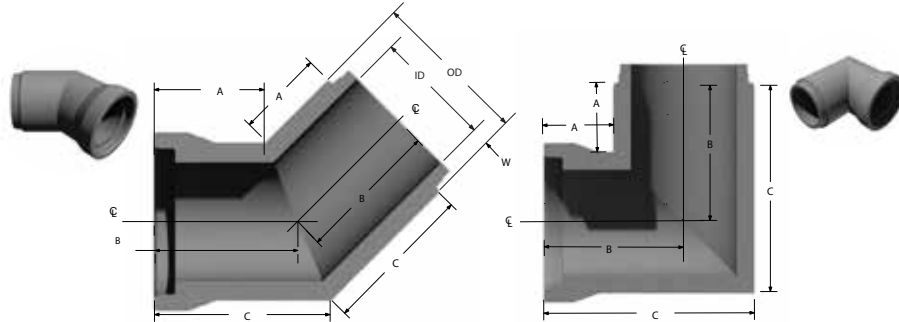

ID (Nominal)	Wall	OD	90° Bends			45° Bends		
			A	B	C	A	B	C
300	70	445	300	522	745	300	392	484
375	76	533	300	566	833	300	410	521
450	83	622	300	612	923	300	429	558
525	89	711	350	706	1061	350	497	645
600	95	800	350	750	1150	350	516	681
675	102	889	350	795	1240	350	534	719
750	108	978	350	839	1328	350	553	755
825	114	1067	350	883	1416	350	571	792
900	121	1156	350	928	1506	350	589	829
975	127	1245	523	1145	1767	887	1145	1403
1050	133	1334	479	1145	1811	869	1145	1421
1200	146	1511	389	1145	1901	832	1145	1458
1350	159	1689	Use 2- 45° Bends			795	1145	1495
1500	171	1867	Use 2- 45° Bends			834	1220	1606
1650	184	2045	Use 2- 45° Bends			797	1220	1643
1800	197	2223	Use 2- 45° Bends			760	1220	1680
1950	190	2362	Use 2- 45° Bends			731	1220	1709
2100	203	2540	Use 2- 45° Bends			694	1220	1746
2250	215	2717	Use 2- 45° Bends			657	1220	1783
2400	229	2896	Use 2- 45° Bends			620	1220	1820
2550	241	3073	Use 2- 45° Bends			584	1220	1856
2700	254	3251	Use 2- 45° Bends			547	1220	1893
3000	279	3606	Use 2- 45° Bends			473	1220	1967
3600	349	4356	Use 2- 45° Bends			462	1220	1976

45° and 90° Bend Dimension

Notes

1. All Bends are manufactured in accordance with CSA-A257.2.
2. Special angle bends are available upon request.
3. All dimensions are in millimeters unless otherwise shown.



Pipe Tee

Main Pipe ID A	Branch Pipe ID B	C	D
300 To 3600	300	300	300
375 To 3600	375	300	300
450 To 3600	450	350	300
525 To 3600	525	350	350
600 To 3600	600	350	350
675 To 3600	675	350	350
750 To 3600	750	350	350
825 To 3600	825	350	350
900 To 3600	900	350	350
975 To 3600	975	350	350
1050 To 3600	1050	350	350
1200 To 3600	1200	350	350
1350 To 3600	1350	300	350
1500 To 3600	1500	305	350

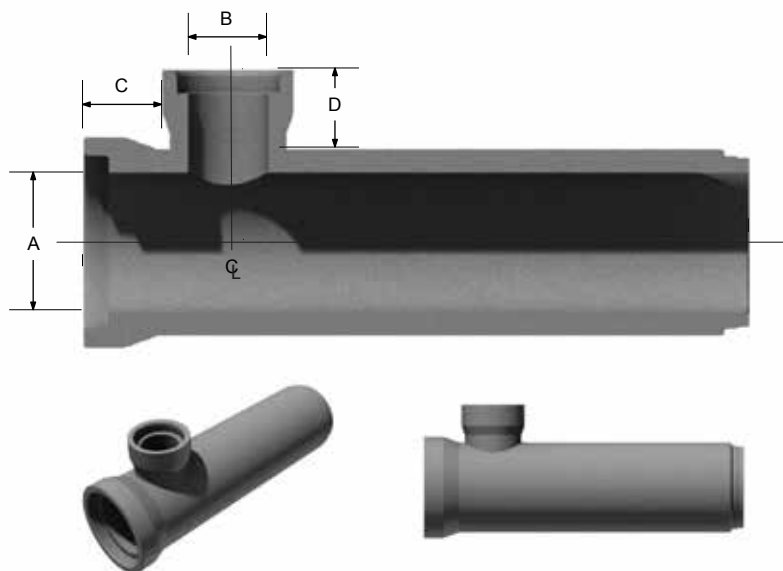

Pipe Wye

Main Pipe ID A	Branch Pipe ID B	C	D	E
300 To 3600	300	400	300	745
375 To 3600	375	400	300	833
450 To 3600	450	400	300	923
525 To 3600	525	400	350	1061
600 To 3600	600	400	350	1150
675 To 3600	675	400	350	1240
750 To 3600	750	400	350	1328
825 To 3600	825	400	350	1416
900 To 3600	900	400	350	1506

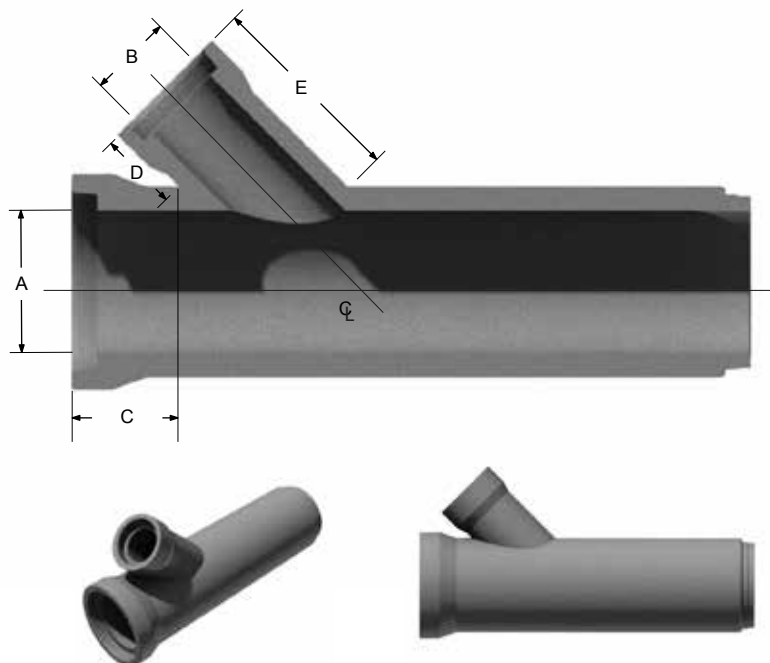

Tee and Wye Dimensions

Notes

1. All wyes and tees are manufactured in accordance with CSA-A257.2.
2. Special design tees and wyes are available upon request.
3. All tee and wye combinations listed above are based on using a full length main pipe.
50-D, 65-D, 100-D and 140-D.
4. All dimensions are in millimeters unless otherwise shown.





“Fillet” Pipe Product

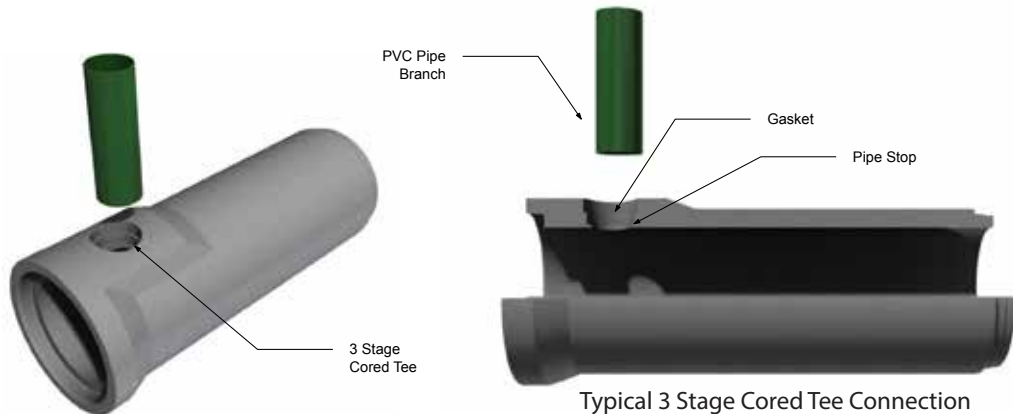

Designated Diameter (mm)	PVC Branch Size (mm)					
300	100	125	150	200		
375	100	125	150	200	250	
450	100	125	150	200	250	300

Standard Pipe Product

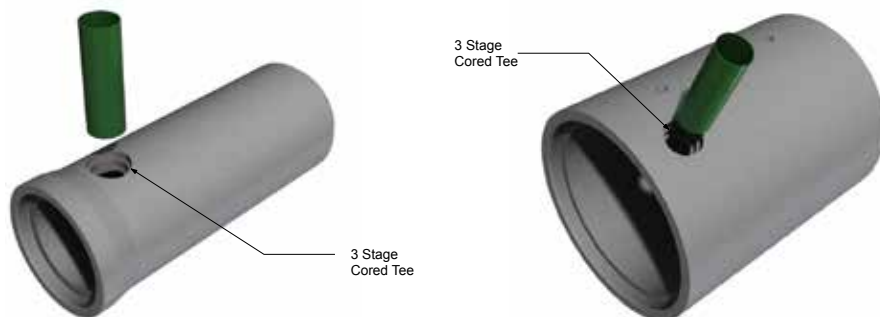

Designated Diameter (mm)	PVC Branch Size (mm)					
300	100					
375	100	125				
450	100	125	150	200		
525	100	125	150	200	250	
600	100	125	150	200	250	
675-3000	100	125	150	200	250	300

3 Stage Cored Tee (for PVC pipe applications)

Notes

1. Tee connection manufactured in accordance with CSA-A257.2.
2. See page 16 for connection type and sizes not detailed.
3. All dimensions are in millimeters unless otherwise shown.



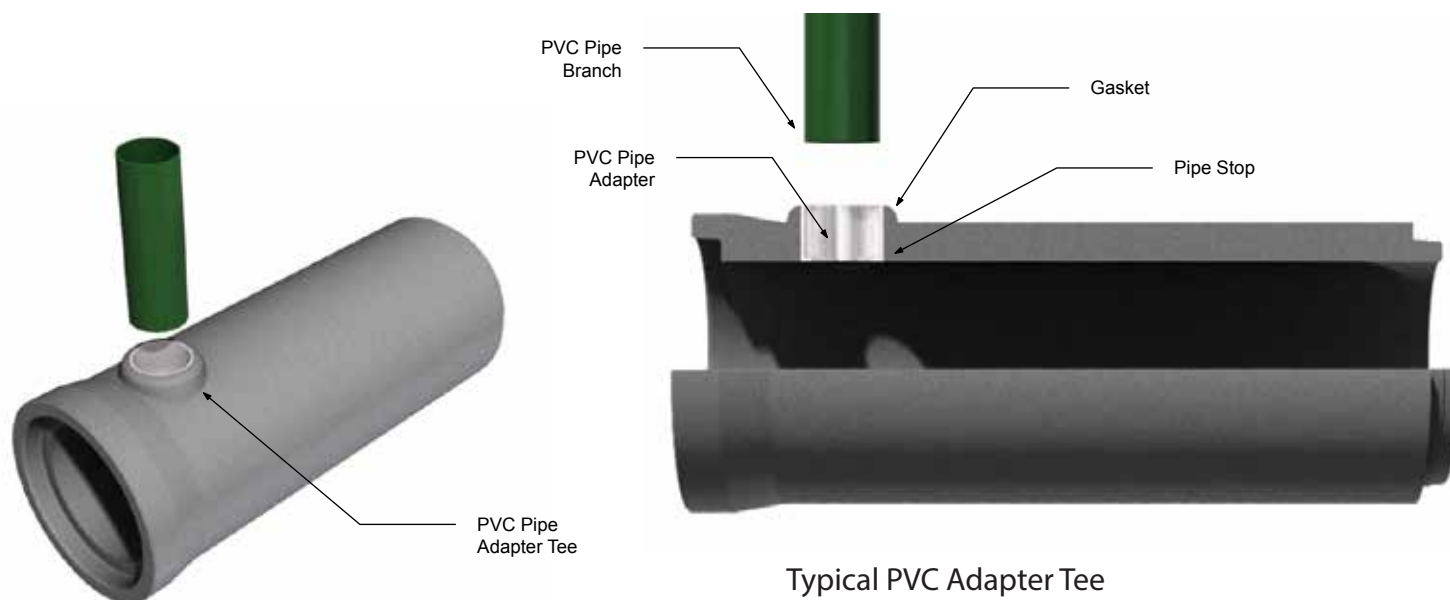

Nominal Diameter (mm)	PVC Branch Size (mm)				
300	125	150	200	250	300
375		150	200	250	300
450				250	300
525	See page 10 for PVC branch sizes not detailed.				300
600	See page 10 for PVC branch sizes not detailed.				300

PVC Adapter Tee 300-600mm

Notes

1. Tee connection manufactured in accordance with CSA-A257.2.
2. All dimensions are in millimeters unless otherwise shown.



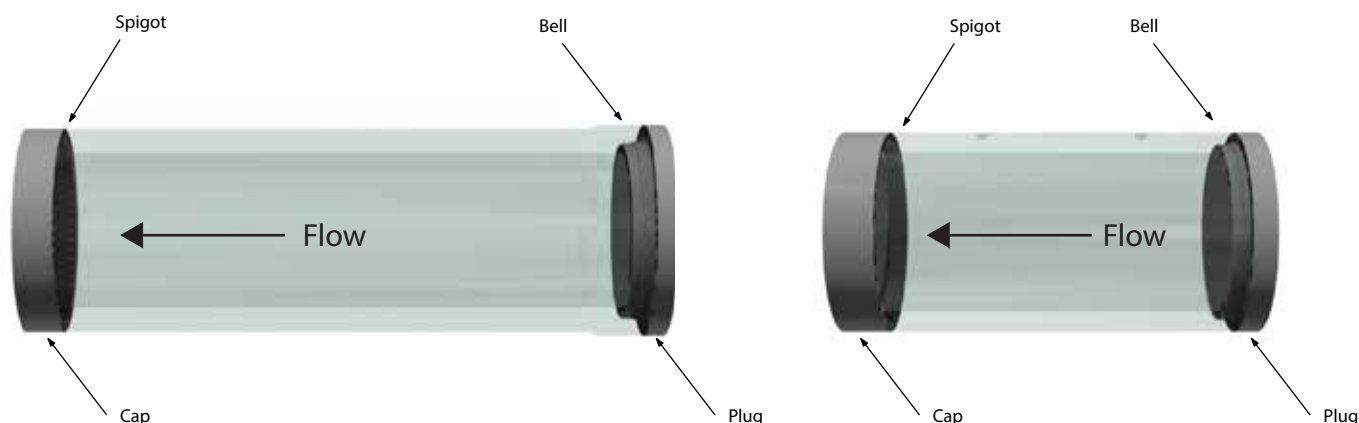

Size	Approximate Mass	
	Plugs	Caps
mm	kg/pc	kg/pc
300	26	122
375	39	167
450	53	242
525	69	270
600	86	325
675	106	384
750	130	472
825	154	527
900	180	618

Size	Approximate Mass	
	Plugs	Caps
mm	kg/pc	kg/pc
975	865	720
1050	989	765
1200	1266	986
1350	1572	1239
1500	1908	1440
1650	2284	1676
1800	2702	1983
1950	3097	2192
2100	3585	2531
2250	4109	2894
2400	4667	3279
2550	5262	3690
2700	5893	4127
3000	7095	5892
3600	10279	8662

Concrete Pipe Plugs and Caps

Notes

- 300 to 1050 mm plugs come complete with one lift point.
- 1200 to 3000 mm plugs and Caps come complete with 2 lift points.
- Alternative precast-in plugs are available upon request. Please contact our engineering department for more detail.





Concentric Reducer



Concentric Increaser



Eccentric Reducer



Eccentric Increaser

Concrete Pipe Reducers and Increasers

Notes

1. All reducers and increasers are manufactured in accordance with CSA A 257.2.
2. Available for all standard pipe diameter applications.



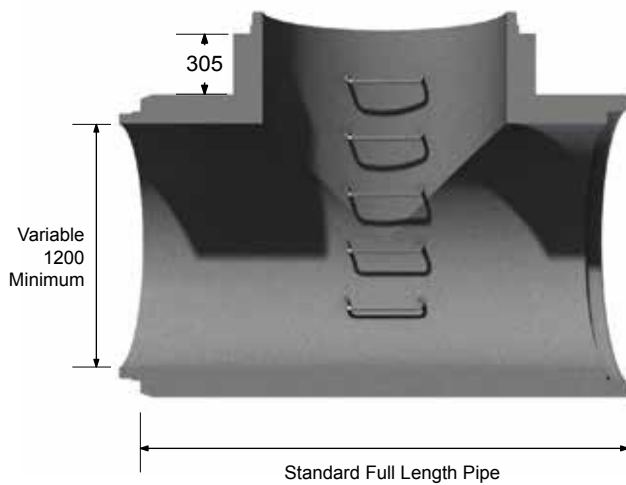
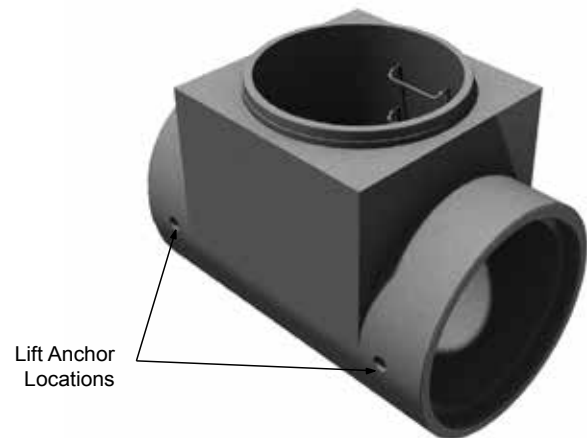
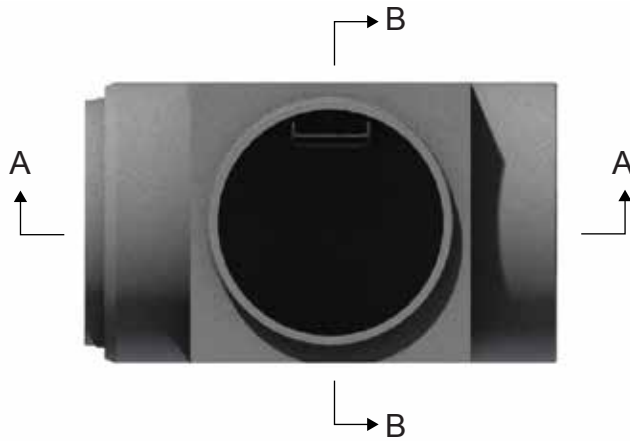

Section A-A

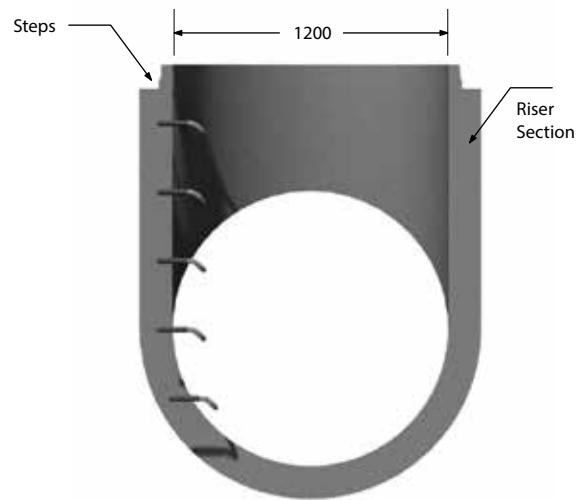

Section B-B

Pipe Maintenance Hole Tees

Notes

1. Manufactured in accordance with OPSD 707.010.
2. Maintenance hole steps as per OPSD 405.010.
3. Contact the M CON engineering department for special design maintenance tee applications.
4. All dimensions are in millimeters unless otherwise shown.



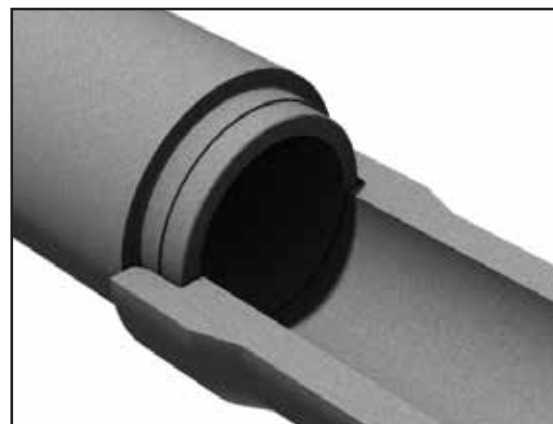
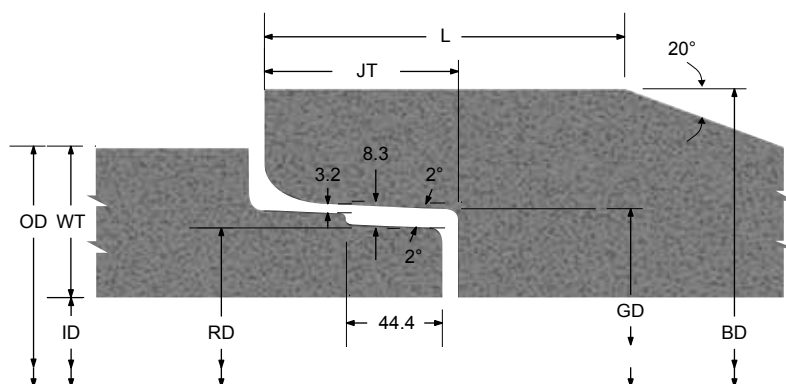

ID (Nominal)	ID (Actual)	OD	WT	BD	JT	RD	GD	L
300	305	444.6	69.8	498.5	88.9	374.1	387.5	165.1
375	381	533.4	76.2	587.4	88.9	461.7	475.2	165.1
450	457	622.0	82.5	701.7	95.3	554.9	568.4	165.1
525	533	710.8	88.9	752.5	88.9	614.1	627.6	177.8
600	610	800.4	95.2	828.7	88.9	690.3	703.8	177.8
675	686	889.2	101.6	904.9	88.9	766.5	780.0	177.8
750	762	977.8	107.9	1003.3	88.9	850.1	863.6	177.8

Pipe Joint Detail 300-750mm

Notes

1. Pre-lubricated rubber gaskets to be used with this pipe joint design.
2. See page 19 for pipe jointing procedure.
3. Manufactured in accordance with CSA-A257.2.
4. All dimensions are in millimeters unless otherwise shown.



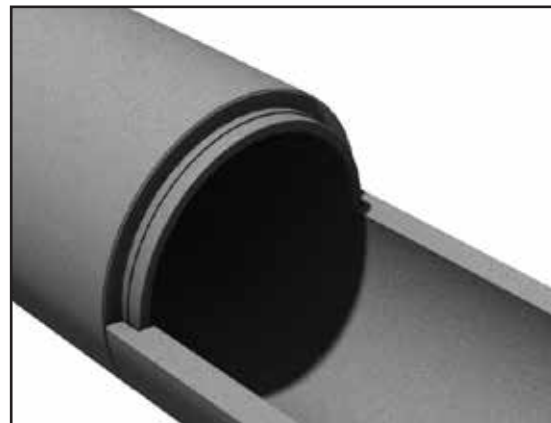
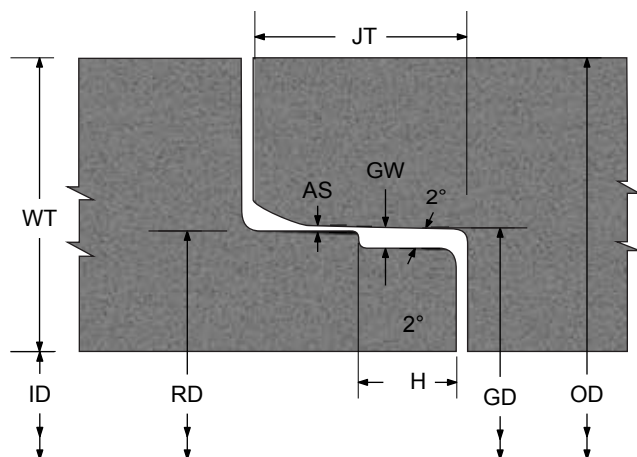

ID (Nominal)	ID (Actual)	OD	WT	JT	RD	GD	AS	GW	H
825	832	1066.6	114.3	88.9	926.3	939.8	3.2	8.3	44.5
900	914	1155.2	120.6	88.9	1002.5	1016.0	3.2	8.3	44.5
975	991	1245.0	127.0	88.9	1078.7	1092.2	3.2	8.3	44.5
1050	1067	1333.7	133.3	107.9	1172.7	1190.9	3.7	11.3	63.5
1200	1220	1512.0	146.0	107.9	1325.1	1343.3	3.7	11.3	63.5
1350	1372	1689.4	158.7	107.9	1470.1	1488.3	3.7	11.3	63.5
1500	1524	1866.8	171.4	120.6	1635.2	1653.4	3.7	11.3	63.5
1650	1676	2044.2	184.1	127.0	1800.3	1818.5	3.7	11.3	63.5
1800	1829	2222.6	196.8	127.0	1959.8	1978.0	3.7	11.3	63.5
1950	1981	2362.0	190.5	127.0	2123.7	2145.5	4.4	13.3	69.8
2100	2134	2540.4	203.2	127.0	2288.8	2310.6	4.4	13.3	69.8
2250	2286	2717.8	215.9	127.0	2453.9	2475.7	4.4	13.3	69.8
2400	2438	2895.6	228.6	127.0	2619.0	2640.8	4.4	13.3	69.8
2550	2591	3073.4	241.3	127.0	2783.8	2805.9	4.4	13.3	69.8
2700	2743	3251.8	254.0	127.0	2949.2	2971.0	4.4	13.3	69.8
3000	3048	3606.8	279.4	152.4	3247.7	3269.5	4.4	13.3	69.8
3600	3658	4356.0	349.0	152.4	3895.4	3917.2	3.7	12.7	50.8

Pipe Joint Detail 825-3600mm

Notes

1. Pre-lubricated rubber gaskets to be used with this pipe joint design.
2. See page 19 for pipe jointing procedure.
3. Manufactured in accordance with CSA-A257.2.
4. All dimensions are in millimeters unless otherwise shown.



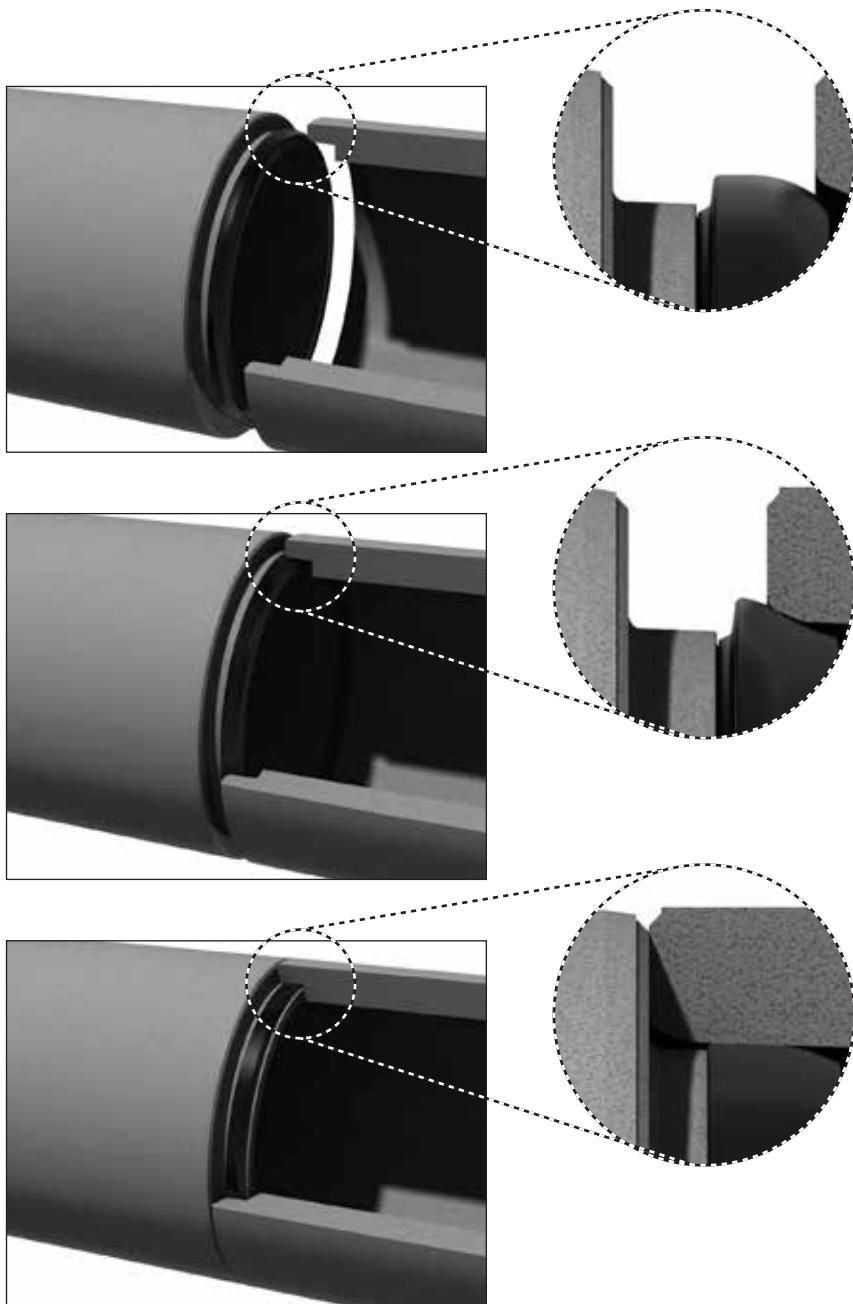

Step 1

Clean all dirt and foreign objects off the bell and spigot. Ensure both the bell and spigot are free of cracks, chips and defects. Carefully stretch the gasket around the spigot with the nose of gasket resting against the step of the spigot and the gasket tube laying on the spigot

Step 2

Align the spigot with the bell. Ensure the gasket is in contact with the entire circumference of both the bell taper and the spigot before fully homing the joint.

Step 3

Engage the spigot into the bell to fully install, locking the joint into place. The self lubricating gasket will roll over the step of the spigot and into the joint recess creating the complete seal.

Joint Procedure - Pre-Lubricated Gaskets

Notes

1. The following above jointing procedure will ensure full optimization of pipe joint performance.
2. This jointing procedure applies to pipe sizes 300 - 3600mm diameter.



SECTION 2

BOX CULVERTS

M CON
PRODUCTS



M CON Products
2150 Richardson Side Road
Ottawa, ON, K0A 1L0, Canada
tf. + 1 800 267 5515
e. sales@mconproducts.com



TABLE OF CONTENTS

SECTION 2 BOX CULVERTS

Mass and Dimensions OPSS Box Sections	21
Mass and Dimension M CON Box Sections	22
Three Sided Culverts	23
Special Box Sections and Fittings	24
Special Box Sections (Optional Cut-Off Wall)	25
Box Section OPSS Bends	26
Box Section Maintenance Hole Tees	27
Box Section Plugs and Caps	28
Box Section OPSS Joint Details	29
Box Section Joint Detail	31
Box Section Joint Procedure - Butyl Tape	32





M CON

PRODUCTS

M CON Products
 2150 Richardson Side Road
 Ottawa, ON, K0A 1L0, Canada
 tf. + 1 800 267 5515
 e. sales@mconproducts.com

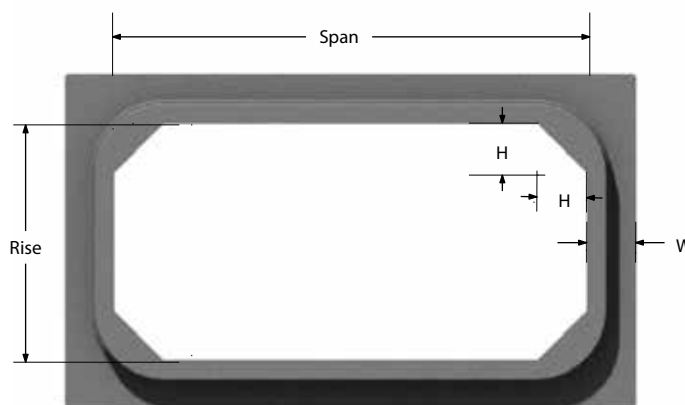
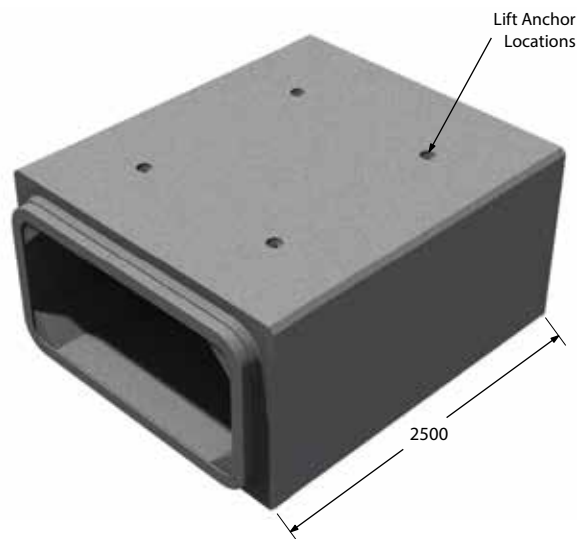

Designated Size Span X Rise	Wall Thickness (W)	Haunch (H)	Waterway Area	Approximate Mass	Lift Anchor Size	Truckload Lots
mm	mm	mm	m ²	kg/pc	ton	pieces
1800 x 900	200	200	1.54	8579	4	5
1800 x 1200	200	200	2.08	9303	4	4
2400 x 1200	200	200	2.80	10895	4	3
2400 x 1500	200	200	3.52	11688	4	3
2400 x 1800	200	200	4.24	12492	4	3
3000 x 1500	250	250	4.38	17021	8	2
3000 x 1800	250	250	5.28	17971	8	2
3000 x 2100	250	250	6.18	18980	8	2
3000 x 2400	250	250	7.08	19931	8	2

Mass and Dimensions OPSS Box Sections

Notes

1. Manufactured in accordance with OPSS 1821 and CHBDC.
2. Contact our engineering department for special design concrete box culvert applications.
3. All dimensions are in millimeters unless otherwise shown.





M CON

PRODUCTS

M CON Products
 2150 Richardson Side Road
 Ottawa, ON, K0A 1L0, Canada
 t. + 1 800 267 5515
 e. sales@mconproducts.com

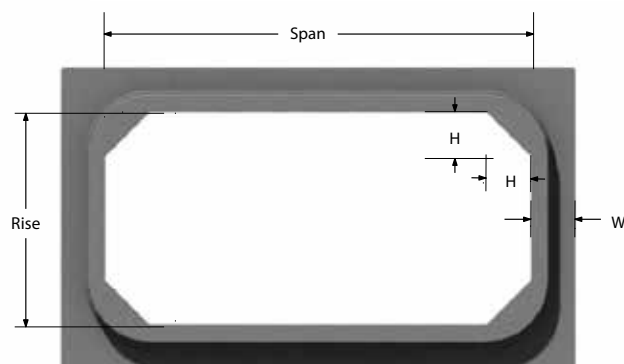
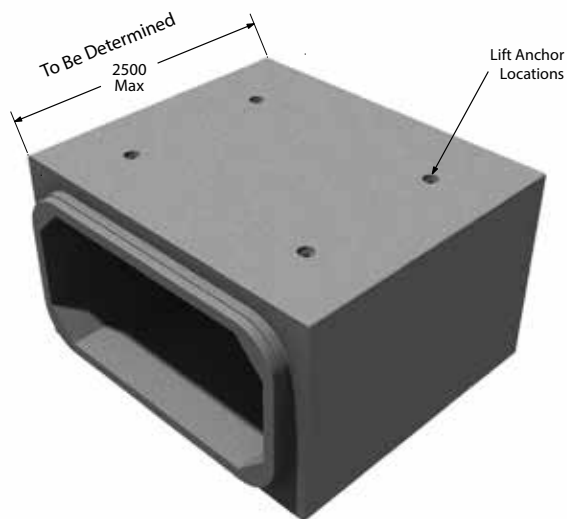

Span	Rise	Wall Thickness (W)	Haunch (H)
mm	mm	mm	mm
1200	900-1200	200	200
1500	1200-1500	200	200
1800	1500-1800	200	200
2400	900	200	200
2400	1200-2400	250/300/350	250/300/350
2700	1200-2700	250/300/350	250/300/350
3000	1200-3000	250/300/350	250/300/350
3300	1200-3300	250/300/350	250/300/350
3600	1200-3600	250/300/350	250/300/350
3900	1200-3900	300/350	300/350
4200	1200-4200	300/350	300/350
4500	1200-4200	300/350	300/350
4800	1200-4200	300/350	300/350
5100	1200-4200	300/350	300/350
5400	1200-4200	300/350	300/350
5700	1200-4200	300/350	300/350
6000	1200-4200	300/350	300/350

Mass and Dimension M CON Box Sections

Notes

1. Designed and manufactured in accordance with the Canadian Highway Bridge Design Code (CHBDC) CAN/CSA-S6.
2. Rise dimension is variable in 300mm increments.
3. Contact our engineering department for special design concrete box section applications.
4. All dimensions are in millimeters unless otherwise shown.





M CON
PRODUCTS

M CON Products
2150 Richardson Side Road
Ottawa, ON, K0A 1L0, Canada
t. + 1 800 267 5515
e. sales@mconproducts.com

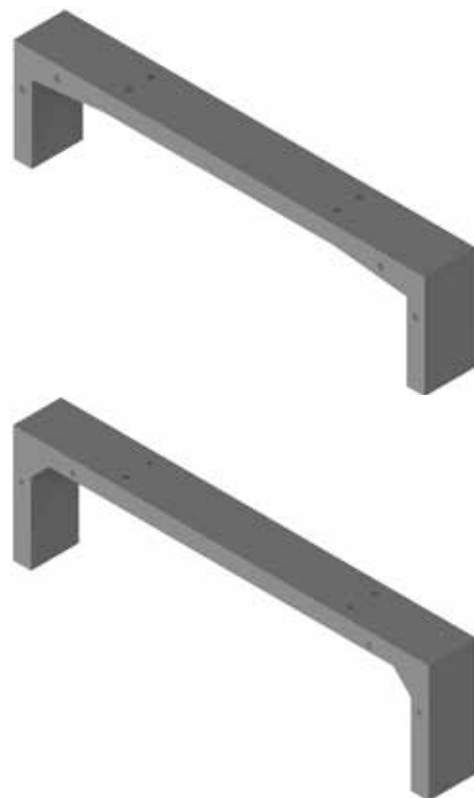
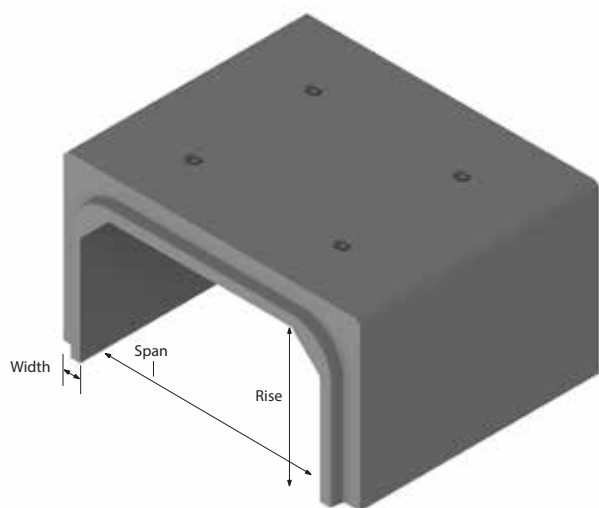

Span	Rise	Wall Thickness (W)	Haunch (X)	Haunch (Y)
mm	mm	mm	mm	mm
600 - 9144	600 - 3600	200 - 450	200 - 3000	200 - 450

Three Sided Culverts

Notes

1. Designed and manufactured in accordance with the Canadian Highway Bridge Design Code (CHBDC) CAN/CSA-S6.
2. Span and rise dimensions are variable in 300mm increments.
3. Footing design available upon request.
4. All dimensions are in millimeters unless otherwise shown.
5. Contact our engineering department for custom design or larger three sided culverts.





M CON Products
2150 Richardson Side Road
Ottawa, ON, K0A 1L0, Canada
t. + 1 800 267 5515
e. sales@mconproducts.com

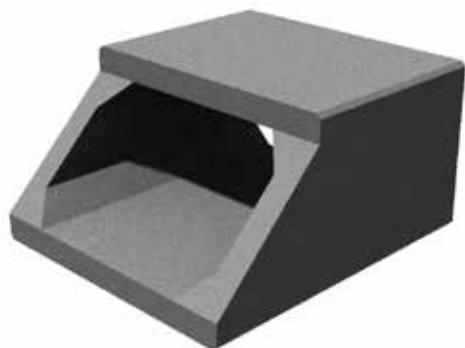

Sloped End

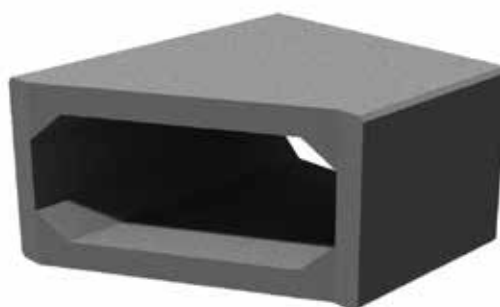

Bevelled End

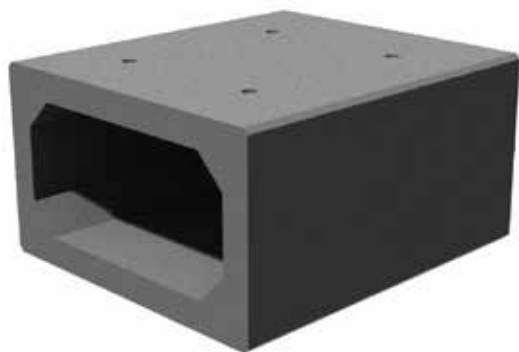

Flush End



Opening for Pipe Connection

Special Box
Sections and
Fittings





M CON
PRODUCTS

M CON Products
2150 Richardson Side Road
Ottawa, ON, K0A 1L0, Canada
t. + 1 800 267 5515
e. sales@mconproducts.com

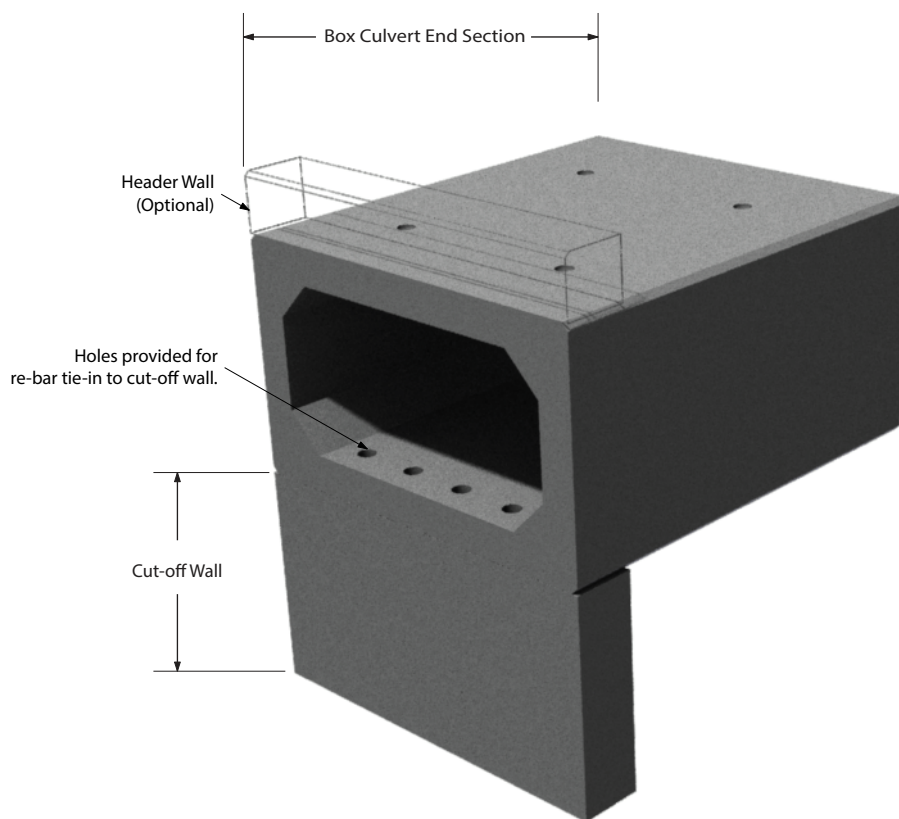

See Note 3

Special Box Sections (Optional Cut-Off Wall)

Notes

1. Contact our engineering department for special design concrete box culvert applications.
2. All dimensions are in millimeters unless otherwise shown.
3. Precast cut-off wall available for all box section end treatment types.





M CON

PRODUCTS

M CON Products
 2150 Richardson Side Road
 Ottawa, ON, K0A 1L0, Canada
 tf. + 1 800 267 5515
 e. sales@mconproducts.com

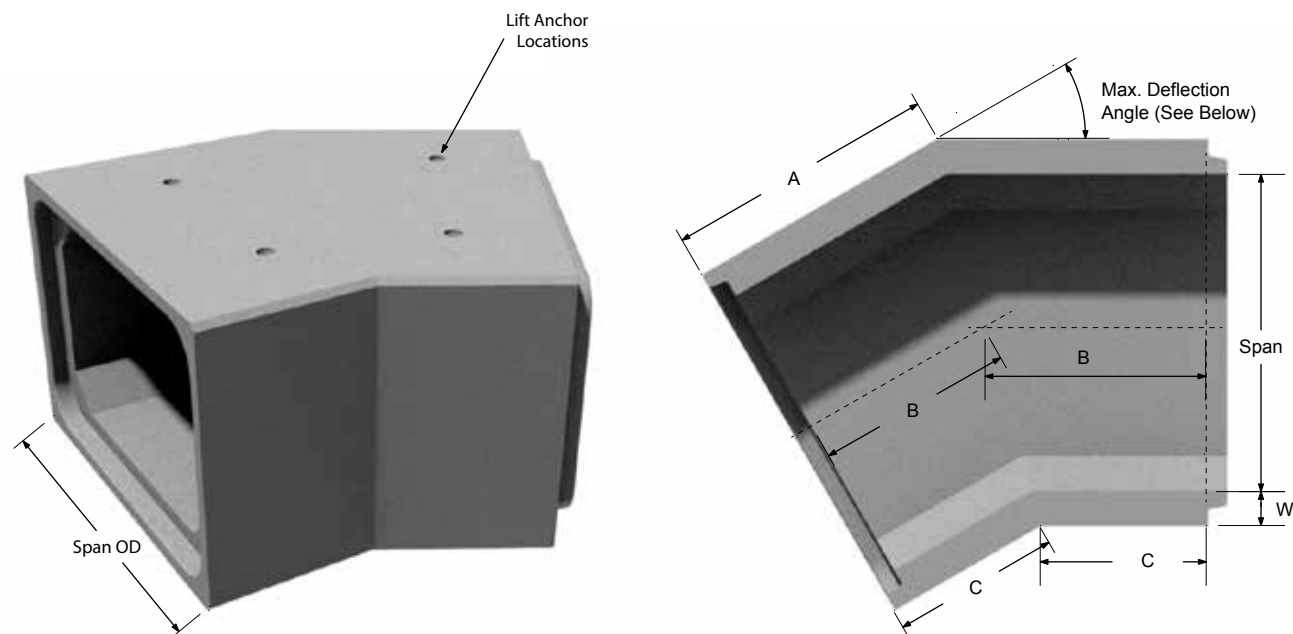

Span	Max. Deflection Angle	Wall Thickness (W)	Span (OD)	A (max.)	B (constant)	C (min.)	Lift Anchor size
mm	degrees	mm	mm	mm	mm	mm	tons
1800	75	200	2200	2094	1250	406	4
2400	60	200	2800	2058	1250	442	4
3000	45	250	3500	1975	1250	525	8

Box Section OPSS Bends

Notes

1. Manufactured in accordance with OPSS 1821 and CHBDC.
2. Above dimensions are based on standard center line length of 2.50 m.
3. Contact our engineering department for additional box bend information and angles not detailed.





M CON
PRODUCTS

M CON Products
2150 Richardson Side Road
Ottawa, ON, K0A 1L0, Canada
t. + 1 800 267 5515
e. sales@mconproducts.com

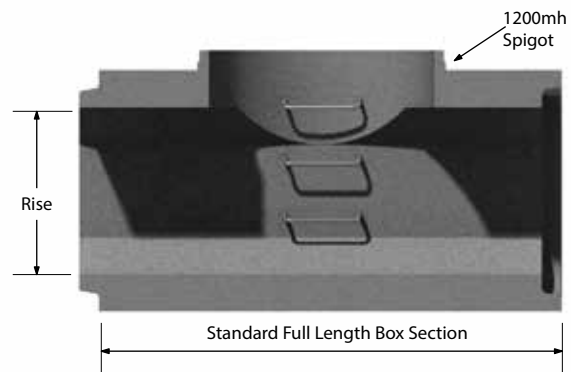
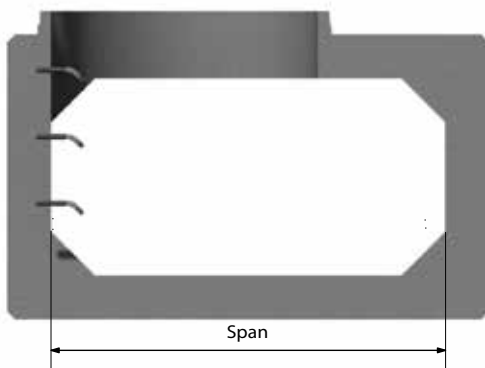
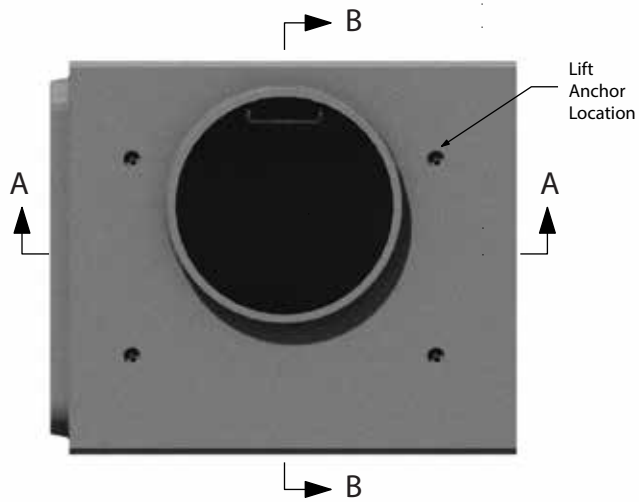

Box Section Maintenance Hole Tees

Notes

1. Manufactured in accordance with OPSS 1821 and CHBDC.
2. Maintenance holes steps as per OPSD 405.010.
3. Above dimensions are in millimeter unless otherwise shown.





M CON
PRODUCTS

M CON Products
2150 Richardson Side Road
Ottawa, ON, K0A 1L0, Canada
t. + 1 800 267 5515
e. sales@mconproducts.com

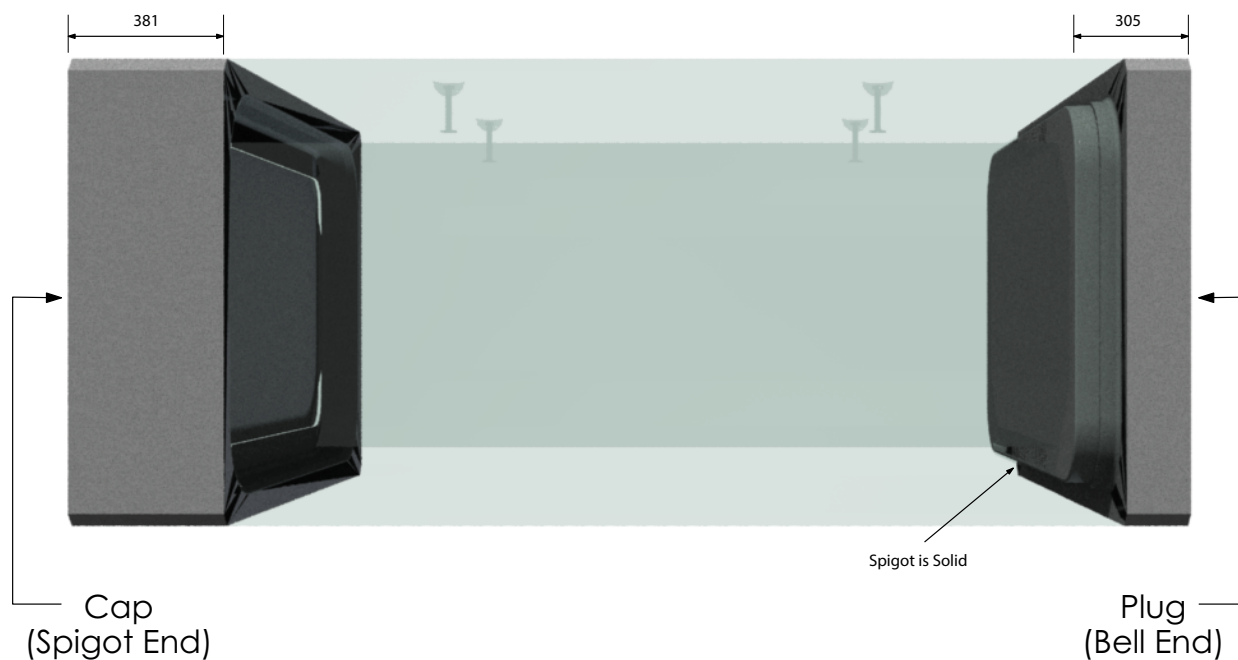

Designated Size Span X Rise	Approximate Mass	
	Plugs	Caps
mm	kg/pc	kg/pc
1800 x 900	1950	1984
1800 x 1200	2439	2567
2400 x 1200	3112	3050
2400 x 1500	3725	3593
2400 x 1800	4352	4409
3000 x 1500	4781	4847
3000 x 1800	5542	5530
3000 x 2100	6302	6214
3000 x 2400	7063	6897
Custom	Varies	Varies

Box Section
Plugs and Caps





M CON Products
 2150 Richardson Side Road
 Ottawa, ON, K0A 1L0, Canada
 tf. + 1 800 267 5515
 e. sales@mconproducts.com

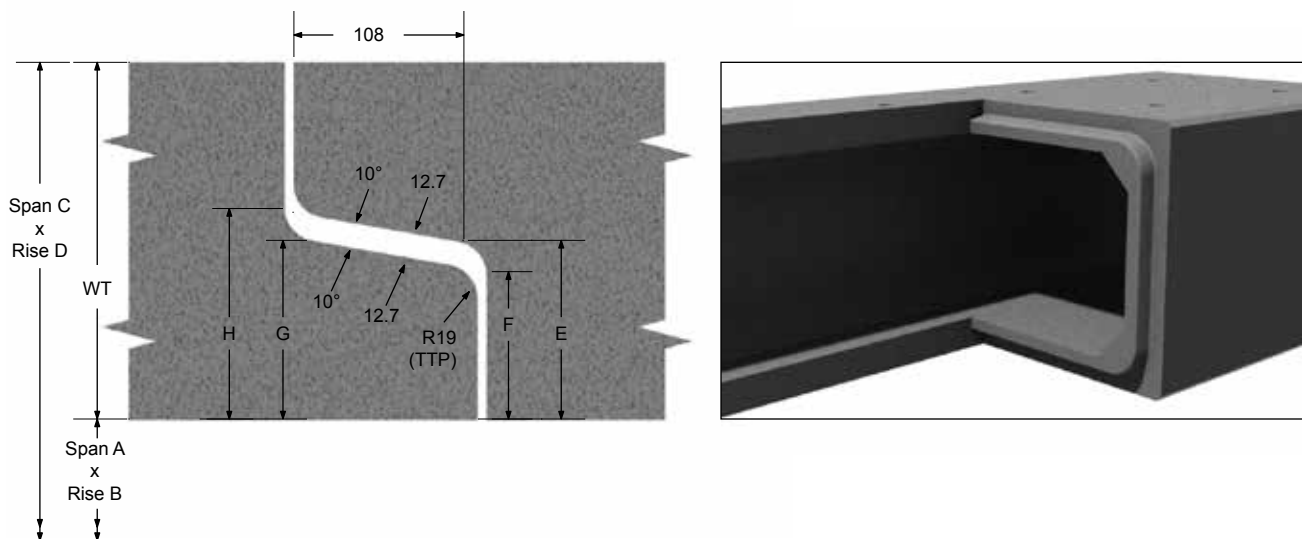

Inside		Outside		E	F	G	H	WT
Span A	Rise B	Span C	Rise D					
1800	1200	2200	1600	96.9	84.0	103.1	116.0	200
2400	1800	2800	2200	96.9	84.0	103.1	116.0	200

Box Section OPSS Joint Details

Notes

1. Box sizes and dimensions conform to those included in OPSS 1821.
2. Rubber gasket joint treatment available upon request.
3. See page 33 for box joint procedures.
4. All dimensions are in millimeters unless otherwise shown.





M CON

PRODUCTS

M CON Products
 2150 Richardson Side Road
 Ottawa, ON, K0A 1L0, Canada
 tf. + 1 800 267 5515
 e. sales@mconproducts.com

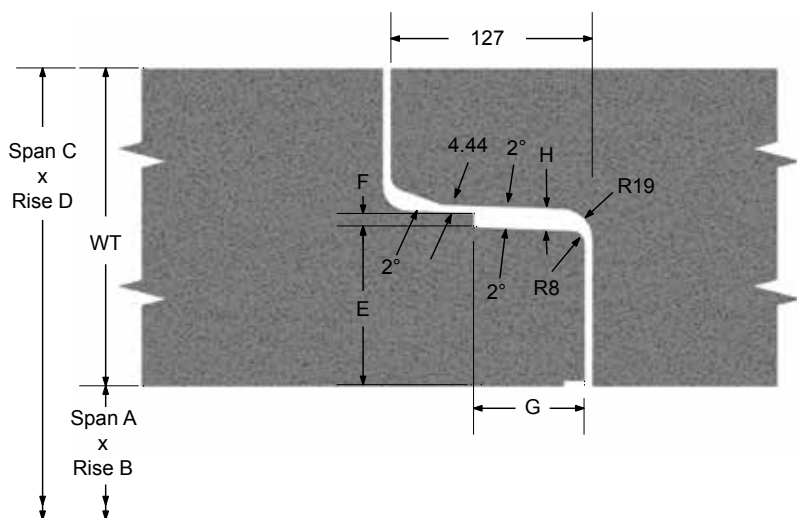

Inside		Outside		E	F	G	H	WT
Span A	Rise B	Span C	Rise D					
1800	900	2200	1300	100.0	8.89	69.85	13.34	200
2400	1200	2800	1600	100.0	8.89	69.85	13.34	200
2400	1500	2800	1900	100.0	8.89	69.85	13.34	200
3000	1500	3500	2000	125.0	8.89	69.85	13.34	250
3000	1800	3500	2300	125.0	8.89	69.85	13.34	250
3000	2100	3500	2600	125.0	8.89	69.85	13.34	250
3000	2400	3500	2900	125.0	8.89	69.85	13.34	250

Box Section OPSS Joint Details

Notes

1. Box sizes and dimensions conform to those included in OPSS 1821.
2. Rubber gasket joint treatment available upon request.
3. See page 32 for box joint procedures.
4. All dimensions are in millimeters unless otherwise shown.





M CON
PRODUCTS

M CON Products
2150 Richardson Side Road
Ottawa, ON, K0A 1L0, Canada
t. + 1 800 267 5515
e. sales@mconproducts.com

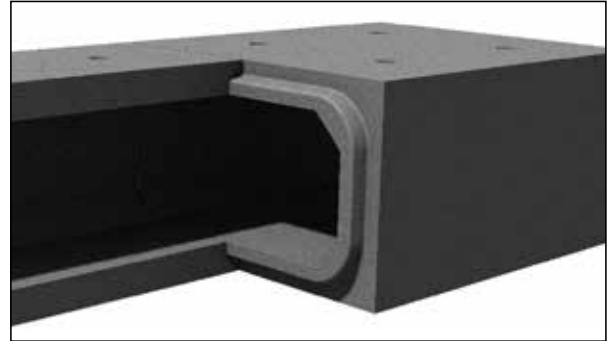
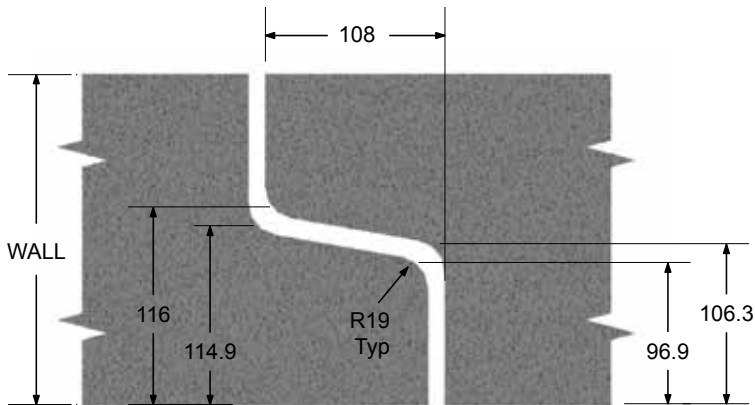

Span	Rise	Wall	Haunch
mm	mm	mm	mm
1200	600 - 1200	200 / 250	200 / 250
1500	600 - 1500	200 / 250	200 / 250
1800	900 - 1800	200 / 250 / 300	200 / 250 / 300
2100	900 - 2100	200 / 250 / 300 / 350	200 / 250 / 300 / 350
2400	900 - 2400	200 / 250 / 300 / 350	200 / 250 / 300 / 350
2700	900 - 2700	200 / 250 / 300 / 350	200 / 250 / 300 / 350
3000	900 - 3000	250 / 300 / 350	250 / 300 / 350
3300	900 - 3300	250 / 300 / 350	250 / 300 / 350
3600	900 - 3600	250 / 300 / 350	250 / 300 / 350
3900	900 - 3600	300 / 350 / 400	300 / 350 / 400
4200	900 - 3600	300 / 350 / 400	300 / 350 / 400
4500	900 - 3600	300 / 350 / 400	300 / 350 / 400
4800	900 - 3600	300 / 350 / 400	300 / 350 / 400
5100+	900 - 3600	300 / 350 / 400	350 / 400 / 450

Box Section Joint Detail

Notes

1. Manufactured in accordance with OPSS 1821 and CHBDC.
2. Rise dimension is variable in 300mm increments.
3. Contact our engineering department for special design concrete box culvert applications.
4. See page 32 for box joint procedures.
5. All dimensions are in millimeters unless otherwise shown.



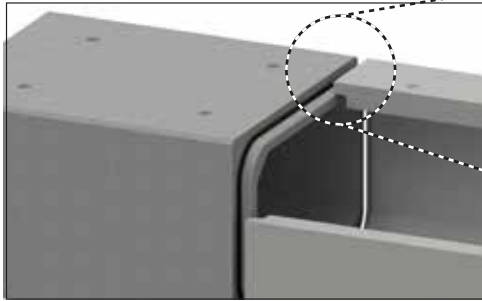

Step 1

Clean all dirt and foreign objects off the bell and spigot. Ensure both the bell and spigot are free of cracks, chips and defects. Apply butyl tape around the perimeter of the spigot.

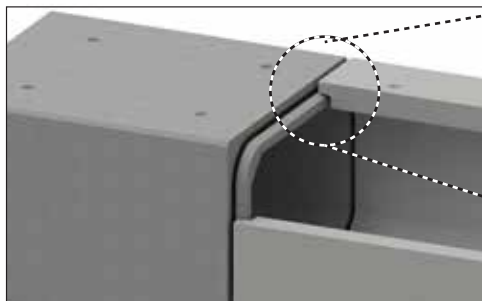

Step 2

Align the spigot with the bell. Ensure the butyl tape is in contact with the entire circumference of both the bell taper and the spigot before fully homing the joint.

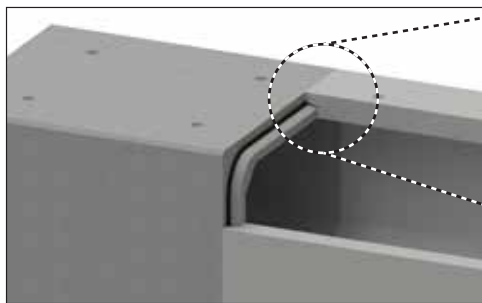

Step 3

Engage the spigot into the bell to fully install, locking the joint into place. The butyl tape will deform between the bell and spigot creating the complete seal.

Box Section Joint Procedure - Butyl Tape

Notes

1. The following above jointing procedure will ensure full optimization of pipe joint performance.
2. This jointing procedure applies to Box Sections available with butyl tape.



SECTION 3 MAINTENANCE HOLES

M CON
PRODUCTS



TABLE OF CONTENTS

SECTION 3 MAINTENANCE HOLES

Maintenance Hole Circular Max Pipe Sizes	35
Maintenance Hole 1200mm Riser and Base Sections	42
Drop Maintenance Holes.	43
Maintenance Hole 1200mm Top Treatments.	44
Maintenance Hole 1500mm Riser and Base Sections	45
Maintenance Hole 1500mm Top Treatments.	46
Maintenance Hole 1800mm Riser and Base Sections	47
Maintenance Hole 1800mm Transition and Top Sections	48
Maintenance Hole 2400mm Riser and Base Slab	49
Maintenance Hole 2400mm Transition and Top Sections	50
Maintenance Hole 3000mm Riser and Base Slab	51
Maintenance Hole 3000mm Transition and Top Sections	52
Maintenance Hole 3600mm Riser and Base Slab	53
Maintenance Hole 3600mm Transition and Flat Cap.	54
Wetcast Maintenance Hole Box Chambers - Max Pipe Size	55
Wetcast Maintenance Hole Box Chambers	56
Drycast Box Maintenance Hole Max Pipe Sizes	57
Drycast Maintenance Hole 2400 x 1800mm Box Chambers	58
Drycast Maintenance Hole 3000 x 1800mm Box Chambers	59
Drycast Maintenance Hole 3000 x 2400mm Box Chambers	60
Maintenance Hole Box Chambers	61
1500mm Flat Cap with 600 x 1200 Ditch Inlet Top.	62
1800mm Flat Cap with 600 x 1200 Ditch Inlet Top.	63
2400mm Flat Cap with 600 x 1200 Ditch Inlet Top.	64
3000mm Flat Cap with 600 x 1200 Ditch Inlet Top.	65
3600mm Flat Cap with 600 x 1200 Ditch Inlet Top.	66
City of Ottawa 1500mm Valve Chamber	67
City of Ottawa Valve Chamber Base Sets.	68
Maintenance, Valve & Meter Box Chambers	69
City of Ottawa T.V.S. Valve Chamber.	70
City of Ottawa Box Valve Chamber.	71
Maintenance Hole Joint Detail 1200-3600mm	72
Maintenance Hole Box Chambers Standard Wall	73
Maintenance Hole Box Chambers Variable Wall Thickness.	74
Maintenance Hole Ottawa Box Chambers Standard Wall	75
Circular Maintenance Hole Jointing Procedure	76
Box Chamber Jointing Procedure	77



MH Size (mm)	Max. Pipe Size For Straight Through	Max. Pipe Size For Right Angle
1200	600 600	450 450
1500	825 825	600 600
1800	1050 1050	825 825
2400	1500 1500	1050 1050
3000	1950 1950	1500 Shift 150mm 1500 Shift 150mm
3600	2400 2400	1950 Shift 150mm 1950 Shift 150mm

Maintenance Hole Circular Max Pipe Sizes

Notes

1. Knockouts for small diameter pipe leads 300mm and smaller can be provided in addition to what is shown.
2. All dimensions are in millimeters unless otherwise shown.



60° Separation

Pipe Size	300	375	450	525	600	675	750	825	900	975	1050	1200	1350	1500
300	1500													
375	1500	1800												
450	1800	1800	1800											
525	1800	1800	1800	2400										
600	1800	1800	2400	2400	2400									
675	1800	2400	2400	2400	2400	2400								
750	2400	2400	2400	2400	2400	2400	2400							
825	2400	2400	2400	2400	2400	3000	3000	3000						
900	2400	2400	2400	2400	2400	3000	3000	3000	3000					
975	2400	2400	2400	2400	3000	3000	3000	3000	3000	3000				
1050	2400	2400	2400	3000	3000	3000	3000	3000	3000	3600	3600			
1200	3000	3000	3000	3000	3000	3000	3000	3600	3600	3600	3600	3600		
1350	3000	3000	3000	3000	3000	3600	3600	3600	3600	3600	3600			
1500	3000	3000	3000	3600	3600	3600	3600	3600	3600	3600				
1650	3600	3600	3600	3600	3600	3600	3600	3600						
1800	3600	3600	3600	3600	3600									
1950	3600	3600	3600											

Maintenance Hole Circular Max Pipe Sizes

Notes

1. Determine all degrees of separation between each set of pipes.
2. If an angle measured does not correspond to any of the tables then round down the angle to the nearest corresponding table.
3. Take each set of pipes and their corresponding angle of separation then compare them to their appropriate table.
4. The largest size of MH will govern - Table is based on OPSD 701.021 (Nov 2014 Rev #4)

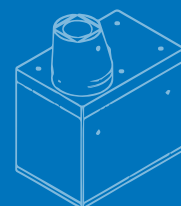



M CON Products
 2150 Richardson Side Road
 Ottawa, ON, K0A 1L0, Canada
 tf. + 1 800 267 5515
 e. sales@mconproducts.com

75° Separation

Pipe Size	300	375	450	525	600	675	750	825	900	975	1050	1200	1350	1500
300	1200													
375	1200	1200												
450	1500	1500	1500											
525	1500	1500	1500	1800										
600	1500	1500	1800	1800	1800									
675	1500	1800	1800	1800	1800	1800								
750	1800	1800	1800	1800	1800	2400	2400							
825	1800	1800	1800	1800	2400	2400	2400	2400						
900	1800	1800	1800	2400	2400	2400	2400	2400	2400					
975	1800	2400	2400	2400	2400	2400	2400	2400	2400	3000				
1050	2400	2400	2400	2400	2400	2400	2400	2400	3000	3000	3000			
1200	2400	2400	2400	2400	2400	2400	3000	3000	3000	3000	3000	3000		
1350	2400	2400	2400	2400	3000	3000	3000	3000	3000	3000	3000	3600	3600	
1500	2400	3000	3000	3000	3000	3000	3000	3000	3000	3600	3600	3600	3600	3600
1650	3000	3000	3000	3000	3000	3000	3600	3600	3600	3600	3600	3600	3600	
1800	3000	3000	3000	3600	3600	3600	3600	3600	3600	3600	3600	3600		
1950	3600	3600	3600	3600	3600	3600	3600	3600	3600	3600	3600			
2100	3600	3600	3600	3600	3600	3600	3600	3600						
2250	3600	3600	3600	3600	3600									
2400	3600	3600												

Maintenance Hole Circular Max Pipe Sizes

Notes

1. Determine all degrees of separation between each set of pipes.
2. If an angle measured does not correspond to any of the tables then round down the angle to the nearest corresponding table.
3. Take each set of pipes and their corresponding angle of separation then compare them to their appropriate table.
4. The largest size of MH will govern - Table is based on OPSD 701.021 (Nov 2014 Rev #4)



90° Separation

Pipe Size	300	375	450	525	600	675	750	825	900	975	1050	1200	1350	1500	1650	1800	1950
300	1200																
375	1200	1200															
450	1200	1200	1200														
525	1200	1200	1500	1500													
600	1200	1500	1500	1500	1500												
675	1500	1500	1500	1500	1800	1800											
750	1500	1500	1500	1500	1800	1800	1800										
825	1500	1500	1800	1800	1800	1800	1800	1800									
900	1800	1800	1800	1800	1800	1800	1800	1800	1800								
975	1800	1800	1800	1800	1800	1800	2400	2400	2400	2400							
1050	1800	1800	1800	1800	1800	2400	2400	2400	2400	2400	2400						
1200	2400	2400	2400	2400	2400	2400	2400	2400	2400	2400	3000	3000					
1350	2400	2400	2400	2400	2400	2400	2400	2400	3000	3000	3000	3000	3000				
1500	2400	2400	2400	2400	2400	2400	3000	3000	3000	3000	3000	3000	3000	3000			
1650	3000	3000	3000	3000	3000	3000	3000	3000	3000	3000	3000	3000	3600	3600	3600		
1800	3000	3000	3000	3000	3000	3000	3000	3000	3000	3000	3600	3600	3600	3600	3600	3600	
1950	3000	3000	3000	3000	3000	3000	3000	3000	3000	3600	3600	3600	3600	3600	3600	3600	3600
2100	3600	3600	3600	3600	3600	3600	3600	3600	3600	3600	3600	3600	3600	3600			
2250	3600	3600	3600	3600	3600	3600	3600	3600	3600	3600	3600	3600	3600				
2400	3600	3600	3600	3600	3600	3600	3600	3600	3600	3600	3600	3600					

Maintenance Hole Circular Max Pipe Sizes

Notes

1. Determine all degrees of separation between each set of pipes.
2. If an angle measured does not correspond to any of the tables then round down the angle to the nearest corresponding table.
3. Take each set of pipes and their corresponding angle of separation then compare them to their appropriate table.
4. The largest size of MH will govern - Table is based on OPSD 701.021 (Nov 2014 Rev #4)



105° Separation

Pipe Size	300	375	450	525	600	675	750	825	900	975	1050	1200	1350	1500	1650	1800	1950	2100	2250	2400
300	1200																			
375	1200	1200																		
450	1200	1200	1200																	
525	1200	1200	1200	1200																
600	1200	1200	1200	1200	1500															
675	1500	1500	1500	1500	1500	1500														
750	1500	1500	1500	1500	1500	1500	1500													
825	1500	1500	1500	1500	1500	1500	1800	1800												
900	1500	1500	1500	1500	1500	1800	1800	1800	1800											
975	1800	1800	1800	1800	1800	1800	1800	1800	1800	1800										
1050	1800	1800	1800	1800	1800	1800	1800	1800	1800	1800	2400	2400								
1200	2400	2400	2400	2400	2400	2400	2400	2400	2400	2400	2400	2400	2400							
1350	2400	2400	2400	2400	2400	2400	2400	2400	2400	2400	2400	2400	2400	3000						
1500	2400	2400	2400	2400	2400	2400	2400	2400	2400	2400	2400	2400	3000	3000	3000					
1650	3000	3000	3000	3000	3000	3000	3000	3000	3000	3000	3000	3000	3000	3000	3000	3000				
1800	3000	3000	3000	3000	3000	3000	3000	3000	3000	3000	3000	3000	3000	3000	3000	3000	3600			
1950	3000	3000	3000	3000	3000	3000	3000	3000	3000	3000	3000	3000	3000	3000	3000	3600	3600	3600		
2100	3600	3600	3600	3600	3600	3600	3600	3600	3600	3600	3600	3600	3600	3600	3600	3600	3600	3600	3600	
2250	3600	3600	3600	3600	3600	3600	3600	3600	3600	3600	3600	3600	3600	3600	3600	3600	3600	3600	3600	
2400	3600	3600	3600	3600	3600	3600	3600	3600	3600	3600	3600	3600	3600	3600	3600	3600	3600	3600	3600	

Maintenance Hole Circular Max Pipe Sizes

Notes

1. Determine all degrees of separation between each set of pipes.
2. If an angle measured does not correspond to any of the tables then round down the angle to the nearest corresponding table.
3. Take each set of pipes and their corresponding angle of separation then compare them to their appropriate table.
4. The largest size of MH will govern - Table is based on OPSD 701.021 (Nov 2014 Rev #4)

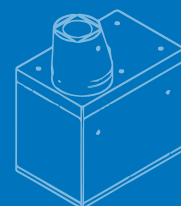



M CON Products
 2150 Richardson Side Road
 Ottawa, ON, K0A 1L0, Canada
 t. + 1 800 267 5515
 e. sales@mconproducts.com

135° Separation

Pipe Size	300	375	450	525	600	675	750	825	900	975	1050	1200	1350	1500	1650	1800	1950	2100	2250	2400	
300	1200																				
375	1200	1200																			
450	1200	1200	1200																		
525	1200	1200	1200	1200																	
600	1200	1200	1200	1200	1200																
675	1500	1500	1500	1500	1500	1500															
750	1500	1500	1500	1500	1500	1500	1500														
825	1500	1500	1500	1500	1500	1500	1500	1500													
900	1800	1800	1800	1800	1800	1800	1800	1800	1800												
975	1800	1800	1800	1800	1800	1800	1800	1800	1800	1800											
1050	1800	1800	1800	1800	1800	1800	1800	1800	1800	1800	1800										
1200	2400	2400	2400	2400	2400	2400	2400	2400	2400	2400	2400	2400									
1350	2400	2400	2400	2400	2400	2400	2400	2400	2400	2400	2400	2400	2400								
1500	2400	2400	2400	2400	2400	2400	2400	2400	2400	2400	2400	2400	2400	2400							
1650	3000	3000	3000	3000	3000	3000	3000	3000	3000	3000	3000	3000	3000	3000	3000						
1800	3000	3000	3000	3000	3000	3000	3000	3000	3000	3000	3000	3000	3000	3000	3000	3000					
1950	3000	3000	3000	3000	3000	3000	3000	3000	3000	3000	3000	3000	3000	3000	3000	3000	3000				
2100	3600	3600	3600	3600	3600	3600	3600	3600	3600	3600	3600	3600	3600	3600	3600	3600	3600	3600			
2250	3600	3600	3600	3600	3600	3600	3600	3600	3600	3600	3600	3600	3600	3600	3600	3600	3600	3600	3600		
2400	3600	3600	3600	3600	3600	3600	3600	3600	3600	3600	3600	3600	3600	3600	3600	3600	3600	3600	3600	3600	3600

Maintenance Hole Circular Max Pipe Sizes

Notes

1. Determine all degrees of separation between each set of pipes.
2. If an angle measured does not correspond to any of the tables then round down the angle to the nearest corresponding table.
3. Take each set of pipes and their corresponding angle of separation then compare them to their appropriate table.
4. The largest size of MH will govern - Table is based on OPSD 701.021 (Nov 2014 Rev #4)





M CON Products
 2150 Richardson Side Road
 Ottawa, ON, K0A 1L0, Canada
 t. + 1 800 267 5515
 e. sales@mconproducts.com

150° - 180° Separation

Pipe Size	300	375	450	525	600	675	750	825	900	975	1050	1200	1350	1500	1650	1800	1950	2100	2250	2400
300	1200																			
375	1200	1200																		
450	1200	1200	1200																	
525	1200	1200	1200	1200																
600	1200	1200	1200	1200	1200															
675	1500	1500	1500	1500	1500	1500														
750	1500	1500	1500	1500	1500	1500	1500													
825	1500	1500	1500	1500	1500	1500	1500	1500												
900	1800	1800	1800	1800	1800	1800	1800	1800	1800											
975	1800	1800	1800	1800	1800	1800	1800	1800	1800	1800										
1050	1800	1800	1800	1800	1800	1800	1800	1800	1800	1800	1800									
1200	2400	2400	2400	2400	2400	2400	2400	2400	2400	2400	2400	2400								
1350	2400	2400	2400	2400	2400	2400	2400	2400	2400	2400	2400	2400	2400							
1500	2400	2400	2400	2400	2400	2400	2400	2400	2400	2400	2400	2400	2400	2400						
1650	3000	3000	3000	3000	3000	3000	3000	3000	3000	3000	3000	3000	3000	3000	3000					
1800	3000	3000	3000	3000	3000	3000	3000	3000	3000	3000	3000	3000	3000	3000	3000	3000				
1950	3000	3000	3000	3000	3000	3000	3000	3000	3000	3000	3000	3000	3000	3000	3000	3000	3000			
2100	3600	3600	3600	3600	3600	3600	3600	3600	3600	3600	3600	3600	3600	3600	3600	3600	3600	3600		
2250	3600	3600	3600	3600	3600	3600	3600	3600	3600	3600	3600	3600	3600	3600	3600	3600	3600	3600	3600	
2400	3600	3600	3600	3600	3600	3600	3600	3600	3600	3600	3600	3600	3600	3600	3600	3600	3600	3600	3600	3600

Maintenance Hole Circular Max Pipe Sizes

Notes

1. Determine all degrees of separation between each set of pipes.
2. If an angle measured does not correspond to any of the tables then round down the angle to the nearest corresponding table.
3. Take each set of pipes and their corresponding angle of separation then compare them to their appropriate table.
4. The largest size of MH will govern - Table is based on OPSD 701.021 (Nov 2014 Rev #4)



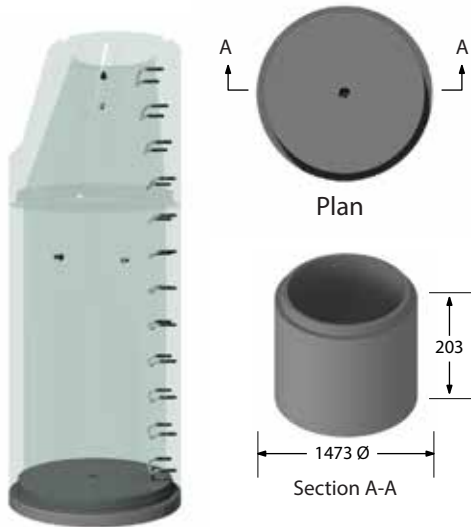

Base Slab

(mass - 759 kg)

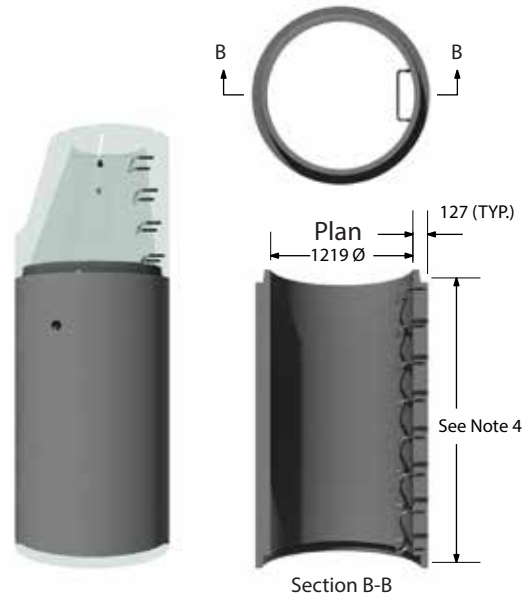

Riser

(mass - 1340 kg/m)

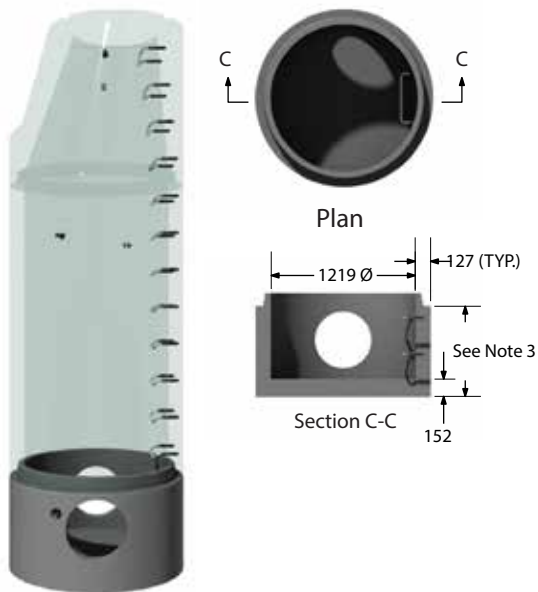

Standard Mono Base

(mass - 720 kg + 1340 kg/m)

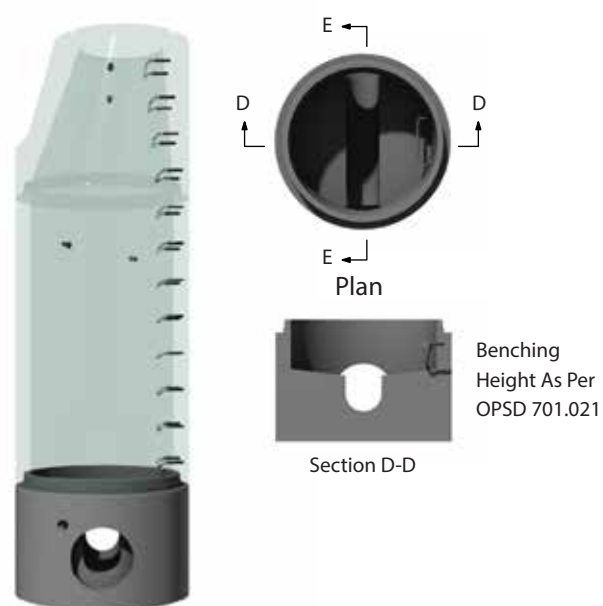

Benched Mono Base

Maintenance Hole 1200mm Riser and Base Sections

Notes

1. Manufactured in accordance with OPSD 701.031 and 701.032.
2. See page 35 for maximum pipe size and alignment angles.
3. Available mono base heights - 610, 762, 914, 1067, 1219, 1372, 1524, 1676 and 1829.
4. Available riser section heights - 305, 610, 914, 1219, 1524 and 1829.
5. Maintenance hole steps (circular hollow aluminum) as per OPSD 405.010.
6. All dimensions are in millimeters unless otherwise shown.
7. 1200 conversion riser requires gasket on both spigot ends.
8. Pre-benching available.



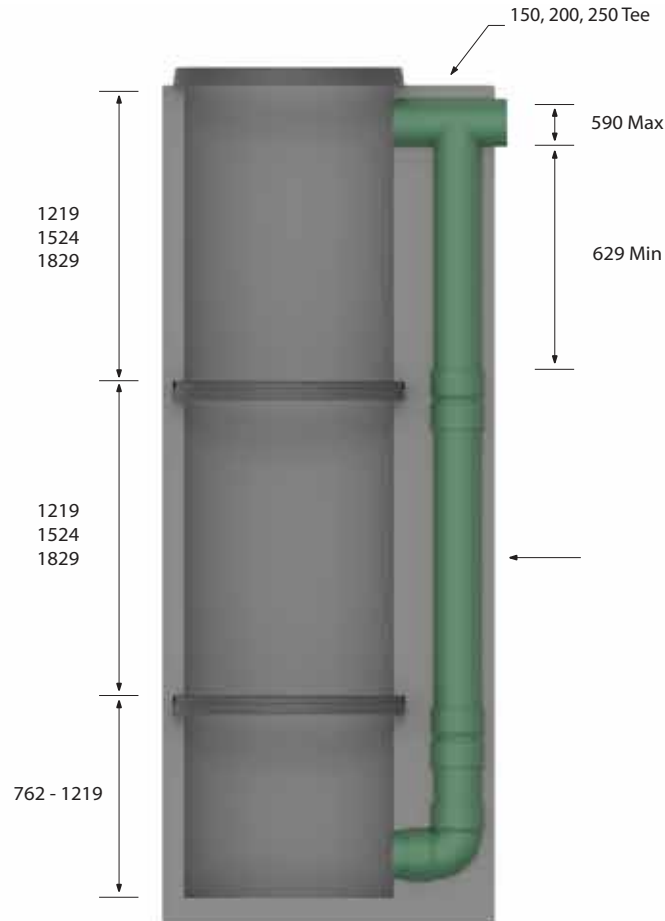

Sewer ID	Drop Pipe ID	Application
200	200	Storm and Sanitary
250	200	Storm and Sanitary
300	250	Storm and Sanitary
375	300	Storm and Sanitary

Drop Maintenance Holes

Notes

1. Concrete shall be placed to undisturbed ground and the outside face of the maintenance hole, but there shall be a minimum of 150mm of 15mpa concrete around the drop pipe.
2. Manufactured in accordance with OPSD 1003.010.
3. Dimensions are in millimetres unless otherwise shown.
4. 300 Drop only includes vertical pipe and 90 degree bend, no tee at top.





Plan

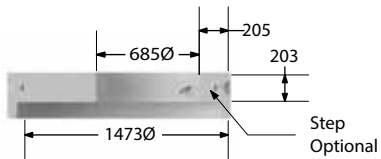

Section A-A



Plan

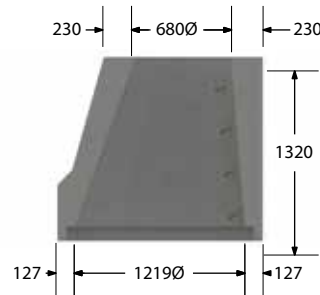

Section B-B



Plan



Section C-C



Flap Cap

(mass - 742 kg)



Cone

(mass - 1975 kg)



Ditch Inlet Flat Cap

(mass - 742 kg + 1267 kg/m)

Maintenance Hole 1200mm Top Treatments

Notes

1. Manufactured in accordance with OPSD 701.030 and 705.030 (ditch inlet top only. See page 88 for ditch inlet information).
2. Maintenance hole steps (circular hollow aluminum) as per OPSD 405.010.
3. All dimensions are in millimeters unless otherwise shown.





(mass - 1786 kg)



Plan

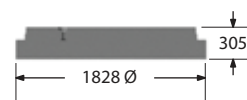

Section A-A

Base Slab



Plan

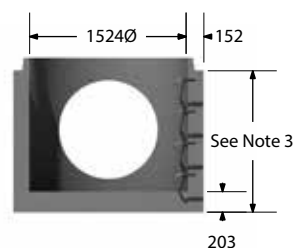

Section C-C

Standard Mono Base



(mass - 2007 kg/m)

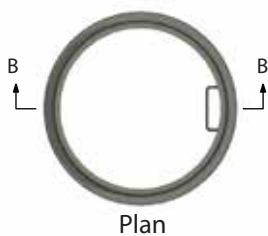

Plan

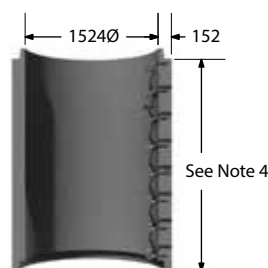

Section B-B

Riser

Maintenance Hole 1500mm Riser and Base Sections

Notes

1. Manufactured in accordance with OPSD 701.040 and 701.041.
2. See page 35 for maximum pipe size and alignment angles.
3. Available mono base heights - 610, 914, 1067, 1219, 1372, 1524, 1676, 1829, 1981, 2134, 2286 and 2438.
4. Available riser section heights - 305, 610, 914, 1219, 1524, 1829, 2134 and 2438.
5. Maintenance hole steps (circular hollow aluminum) as per OPSD 405.010.
6. All dimensions are in millimeters unless otherwise shown.
7. Pre-benching available.

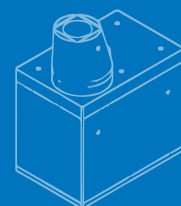

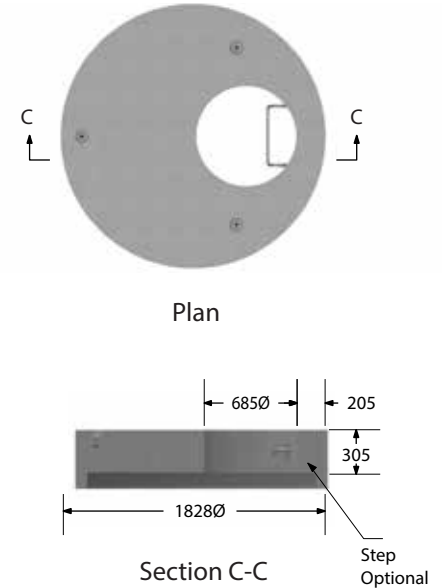
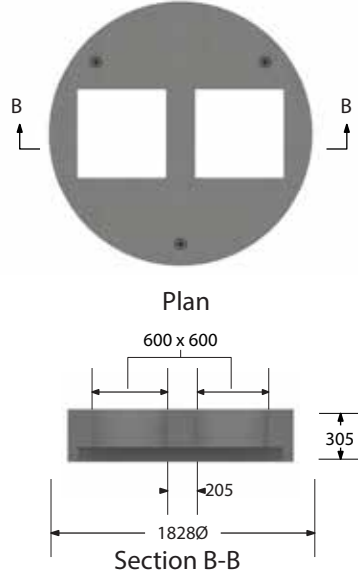
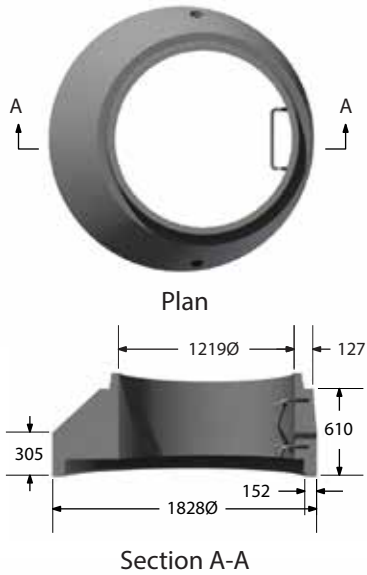

Transition
 (mass - 1633 kg)



Twin Inlet Flat Cap
 (mass - 1600 kg)



Flat Cap
 (mass - 1829 kg)

Maintenance Hole 1500mm Top Treatments

Notes

1. Manufactured in accordance with OPSD 701.040 and 703.011 and 703.021.
2. Maintenance hole steps (circular hollow aluminum) as per OPSD 405.010.
3. All dimensions are in millimeters unless otherwise shown.

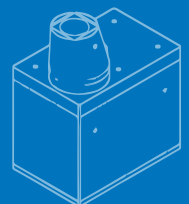



(mass - 2540 kg)

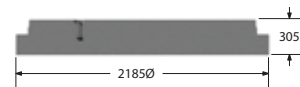
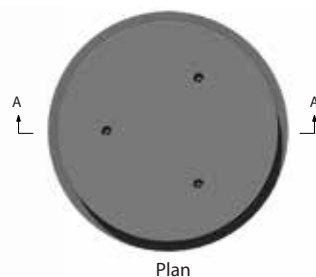

Section A-A

Base Slab

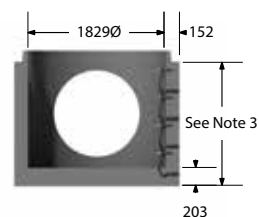
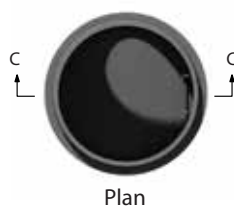

Section C-C

Standard Mono Base



(mass - 2846 kg/m)

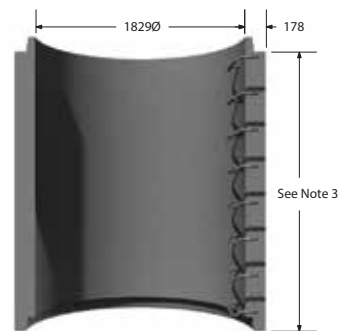
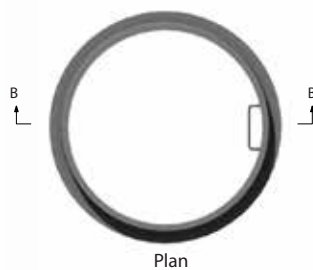

Section B-B

Riser

Maintenance Hole 1800mm Riser and Base Sections

Notes

1. Manufactured in accordance with OPSD 701.051.
2. See page 35 for maximum pipe size and alignment angles.
3. Available mono base heights - 610, 914, 1067, 1219, 1372, 1524, 1676, 1829, 1981, 2134, 2286 and 2438.
4. Available riser section heights - 305, 610, 914, 1219, 1524, 1829, 2134 and 2438.
5. Maintenance hole steps (circular hollow aluminum) as per OPSD 405.010.
6. All dimensions are in millimeters unless otherwise shown.

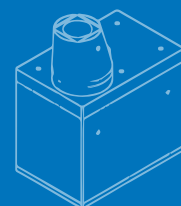



Plan



Plan

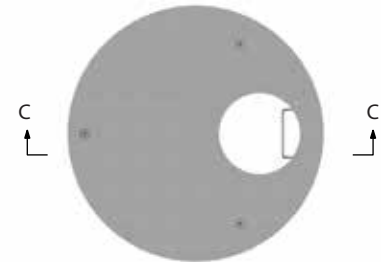

Plan

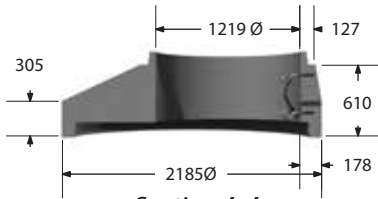

Section A-A

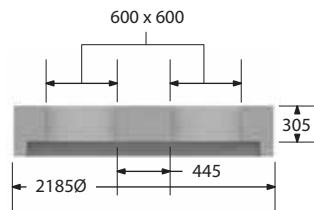

Section B-B

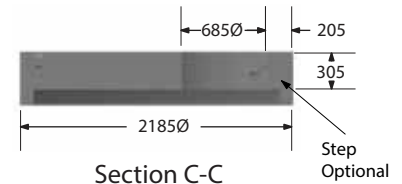

Section C-C



Transition

(mass - 2570 kg)



Twin Inlet Flat Cap

(mass - 2430 kg)



Flap Cap

(mass - 2704 kg)

Maintenance Hole 1800mm Transition and Top Sections

Notes

1. Manufactured in accordance with OPSD 701.050, 703.012 and 703.022.
2. Maintenance hole steps (circular hollow aluminum) as per OPSD 405.010.
3. All dimensions are in millimeters unless otherwise shown.

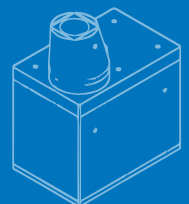

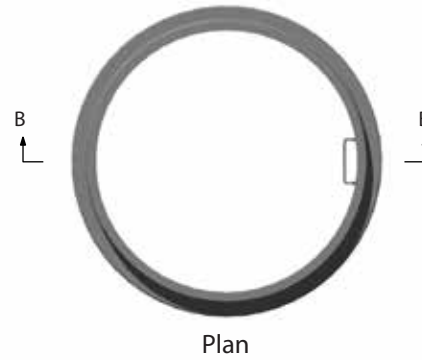
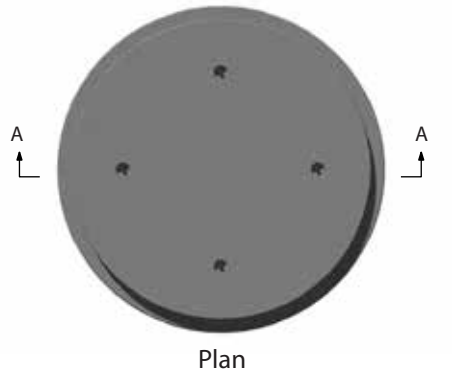

Section A-A

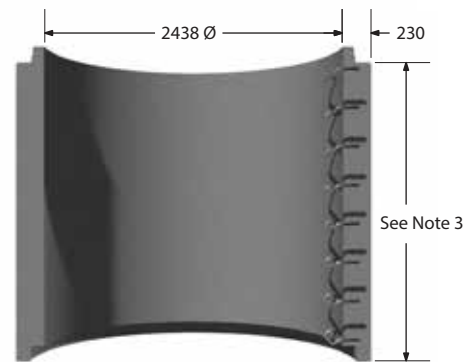

Section B-B

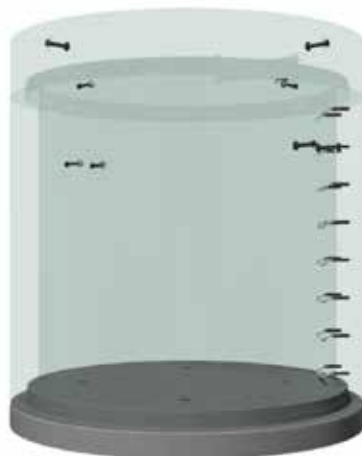

Base Slab

(mass - 4480 kg)



Riser

(mass - 4866 kg/m)

Maintenance Hole 2400mm Riser and Base Slab

Notes

1. Manufactured in accordance with OPSD 701.061.
2. See page 35 for maximum pipe size and alignment angles.
3. Available riser section heights - 610, 914, 1219, 1524, 1829, 2134, and 2438.
4. Maintenance hole steps (circular hollow aluminum) as per OPSD 405.010.
5. All dimensions are in millimeters unless otherwise shown.
6. 1200 conversion riser requires gasket on both spigot ends.

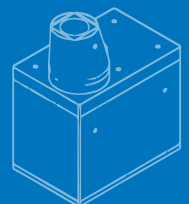



Plan



Plan

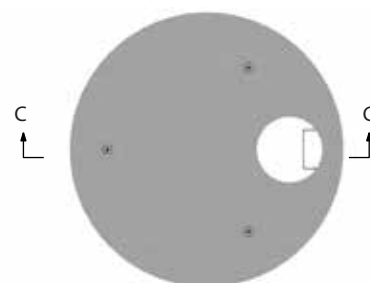

Plan

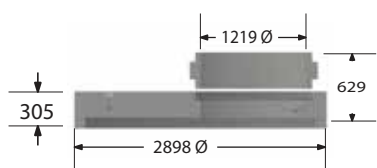

Section A-A

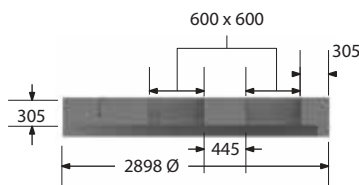

Section B-B

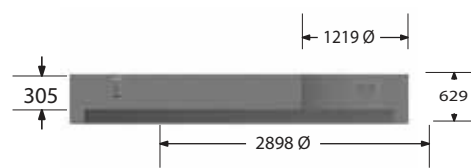

Section C-C



Transition

(mass - 4668 kg)



Twin Inlet Flat Cap

(mass - 4655 kg)



Flat Cap

(mass - 4930 kg)

Maintenance Hole 2400mm Transition and Top Sections

Notes

1. Manufactured in accordance with OPSD 701.060 and 703.013, and 703.023.
2. Maintenance hole steps (circular hollow aluminum) as per OPSD 405.010.
3. All dimensions are in millimeters unless otherwise shown.

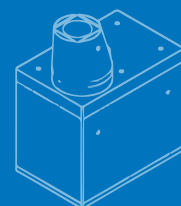

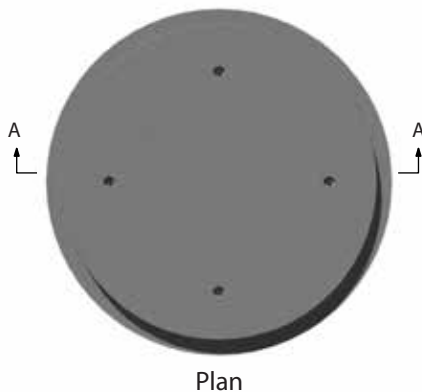

Plan

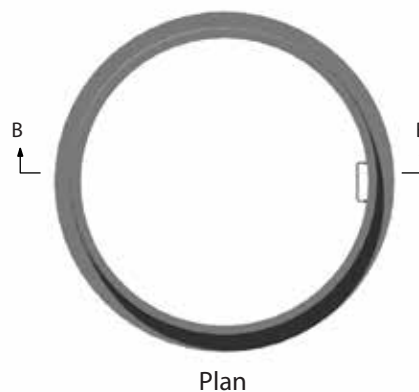

Plan

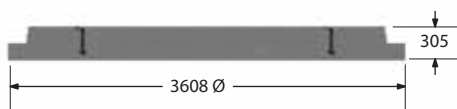

Section A-A

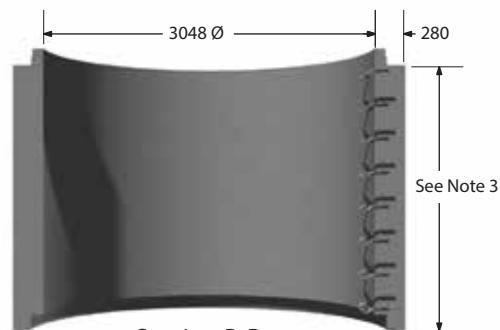

Section B-B



Base Slab

(mass - 6944 kg)



Riser

(mass - 7400 kg/m)

Maintenance Hole 3000mm Riser and Base Slab

Notes

1. Manufactured in accordance with OPSD 701.071.
2. See page 35 for maximum pipe size and alignment angles.
3. Available riser section heights - 610, 914, 1219, 1524, 1829, 2134, and 2438.
4. Maintenance hole steps (circular hollow aluminum) as per OPSD 405.010.
5. All dimensions are in millimeters unless otherwise shown.

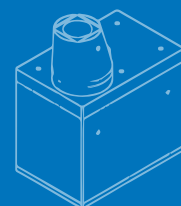



Plan

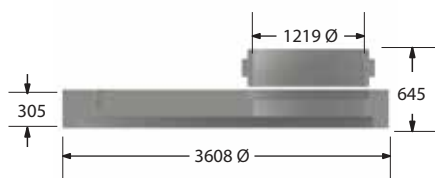

Section A-A



Plan

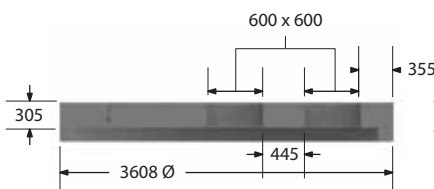

Section B-B

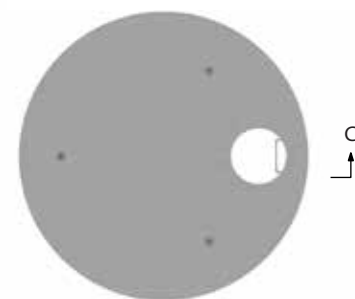

Plan

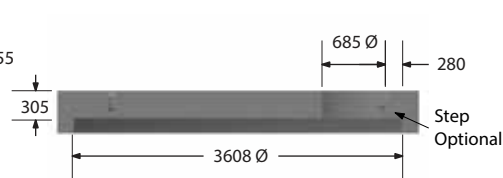

Section C-C



Transition

(mass - 7664 kg)



Twin Inlet Flat Cap

(mass - 7945 kg)



Flat Cap

(mass - 7684 kg)

Maintenance Hole 3000mm Transition and Top Sections

Notes

1. Manufactured in accordance with OPSD 701.070 and 703.014, and 703.024.
2. Maintenance hole steps (circular hollow aluminum) as per OPSD 405.010.
3. All dimensions are in millimeters unless otherwise shown.



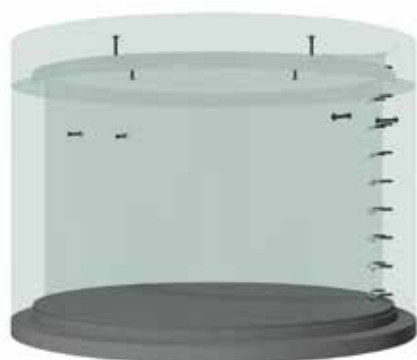
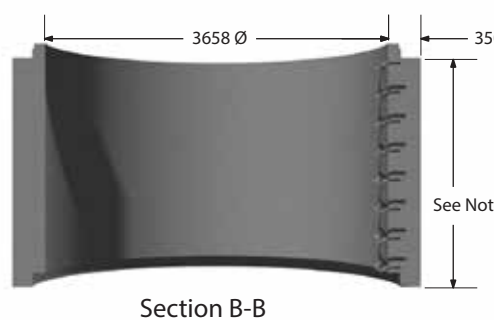
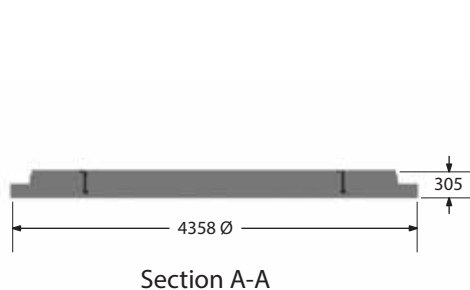
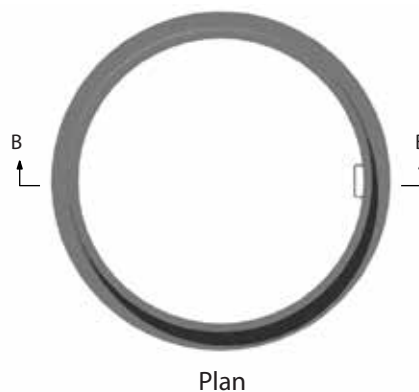
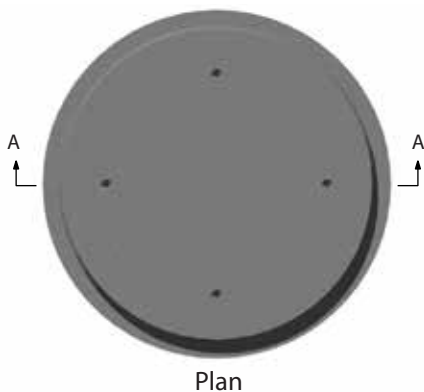

Base Slab
 (mass - 10140 kg)



Riser
 (mass - 10808 kg/m)

Maintenance Hole 3600mm Riser and Base Slab

Notes

1. Manufactured in accordance with OPSD 701.081.
2. See page 35 for maximum pipe size and alignment angles.
3. Available riser section heights - 610, 914, 1219, 1524, 1829, 2134, and 2438.
4. Maintenance hole steps (circular hollow aluminum) as per OPSD 405.010.
5. All dimensions are in millimeters unless otherwise shown.

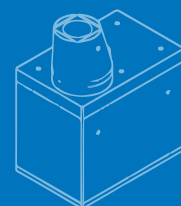

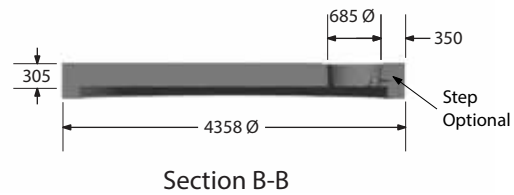
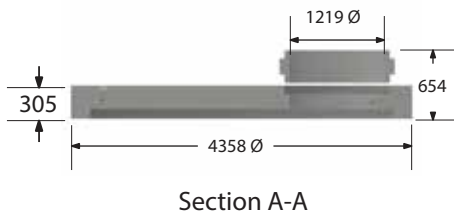
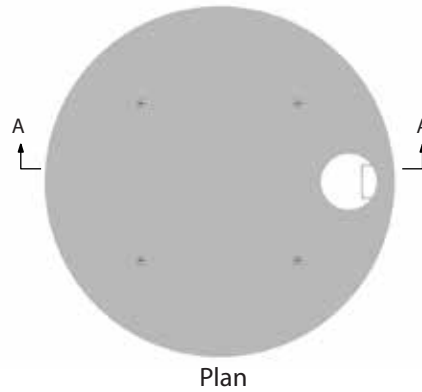
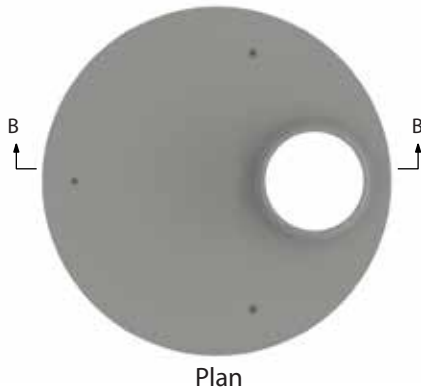

(mass - 11932 kg)



(mass - 10500 kg)







Maintenance Hole 3600mm Transition and Flat Cap

Notes

1. Manufactured in accordance with OPSD 701.080 and 701.015.
2. Maintenance hole steps (circular hollow aluminum) as per OPSD 405.010.
3. All dimensions are in millimeters unless otherwise shown.

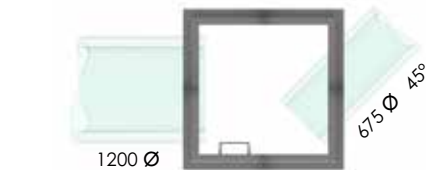

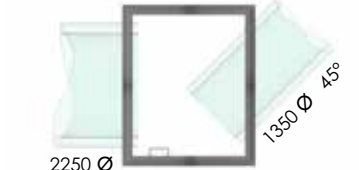
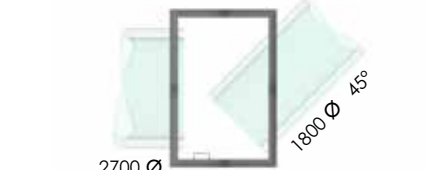
Max Pipe Size Per Given Wall Size (Perpendicular or 45°)

<p>1219 Wall</p>  <p>750 Ø 375 Ø 45°</p>	<p>1524 Wall</p>  <p>975 Ø 525 Ø 45°</p>	<p>1829 Wall</p>  <p>1200 Ø 675 Ø 45°</p>
<p>2438 Wall</p>  <p>1800 Ø 1050 Ø 45°</p>	<p>3048 Wall</p>  <p>2250 Ø 1350 Ø 45°</p>	<p>3810 Wall</p>  <p>2700 Ø 1800 Ø 45°</p>
<p>4270 Wall</p>  <p>3000 Ø 2100 Ø 45°</p>		

Wetcast Maintenance Hole Box Chambers - Max Pipe Size

Notes

1. Designed in accordance with CSA S6 - CHBDC.
2. Chamber depth and connecting pipe size will determine chamber size and wall thickness.
3. See page 44 for 1200mm tapered top details.
4. Maintenance hole steps are circular hollow aluminum as per OPSD 405.010
5. All dimensions are in millimeters unless otherwise shown.

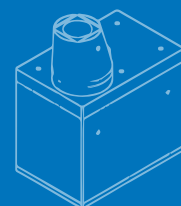

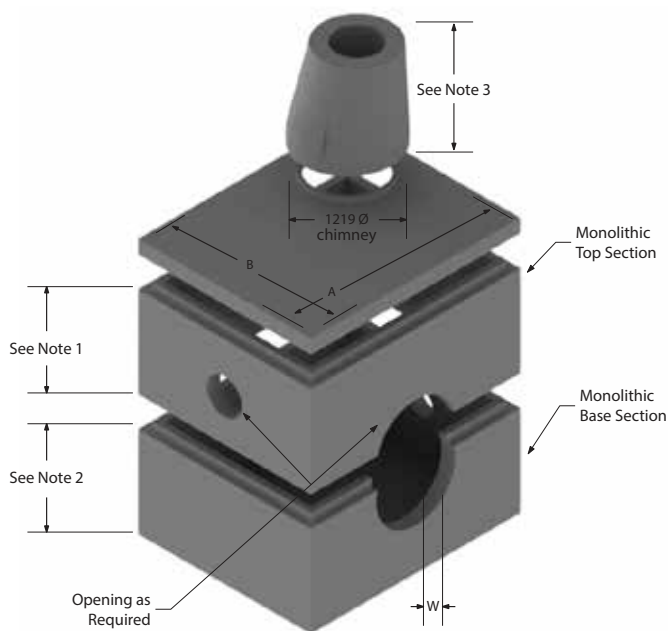





Box Name	Inside Dimensions	Outside Dimensions		Top Slap Thickness	Bott. Slap Thickness	Wall (W) Thickness
		A	B			
M-3-3	914 x 914	1218	1218	152	152	152
M-4	1219 x 1219	1677	1677	229	229	229
M-5	1524 x 1829	1982	2287	229	229	229
M-5.5	1829 x 1829	2287	2287	229	229	229
M-6.5	1829 x 2438	2287	2896	229	229	229
M-7.5	1829 x 3048	2287	3506	229	229	229
M-8	2438 x 2438	2896	2896	254	254	229
M-9	2438 x 3048	2896	3506	254	254	229
M-9.5	3048 x 3048	3506	3506	254	254	229
M-10	2438 x 3810	2896	4268	254	254	229
M-11	3048 x 3810	3506	4268	254	254	229
M-12	3810 x 3810	4260	4260	254	254	229
M-13	2438 x 4270	2896	4728	254	254	229
M-14	3048 x 4270	3506	4728	254	254	229
M-15	3810 x 4270	4260	4728	300	300	229
M-16	4270 x 4270	4728	4728	300	300	229

Wetcast Maintenance Hole Box Chambers

Notes

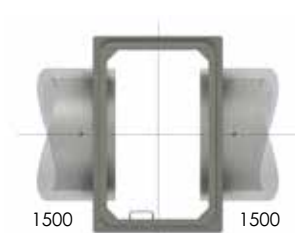
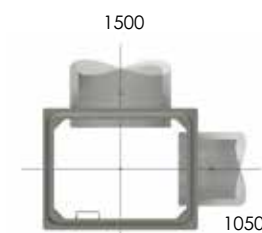
1. Manufactured in accordance with OPSS 1351.
2. Top Section heights @ 152mm increments.
Bottom section heights at 152mm increments.
3. See page 44 for 1200mm tapered top details.
4. Maintenance hole steps are circular hollow aluminum as per OPSS 405.010
5. All dimensions are in millimeters unless otherwise shown.
6. Mono top sections available when required.

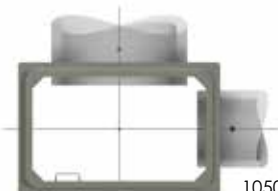

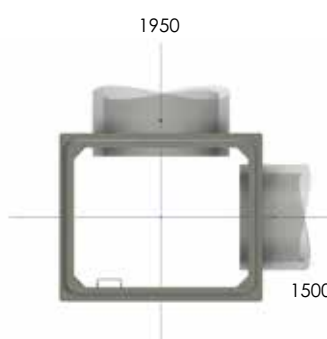
MH Size (mm)	Max. Pipe Size For Straight Through	Max. Pipe Size For Right Angle
2400 x 1800	 <p>1500 1500</p>	 <p>1500 1050</p>
3000 x 1800	 <p>1950 1950</p>	 <p>1950 1050</p>
3000 x 2400	 <p>1950 1950</p>	 <p>1950 1500</p>

Drycast Box Maintenance Hole Max Pipe Sizes

Notes

1. Knockouts for small diameter pipe leads 300mm and smaller can be provided in addition to what is shown.
2. All dimensions are in millimeters unless otherwise shown.



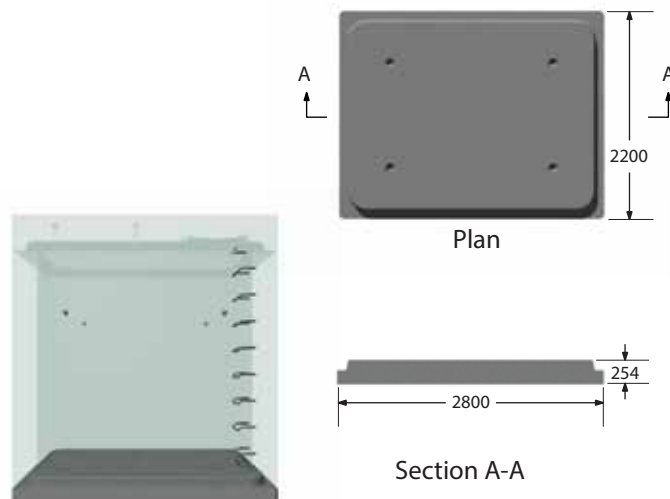

Base Slab
 (mass - 3180 kg)

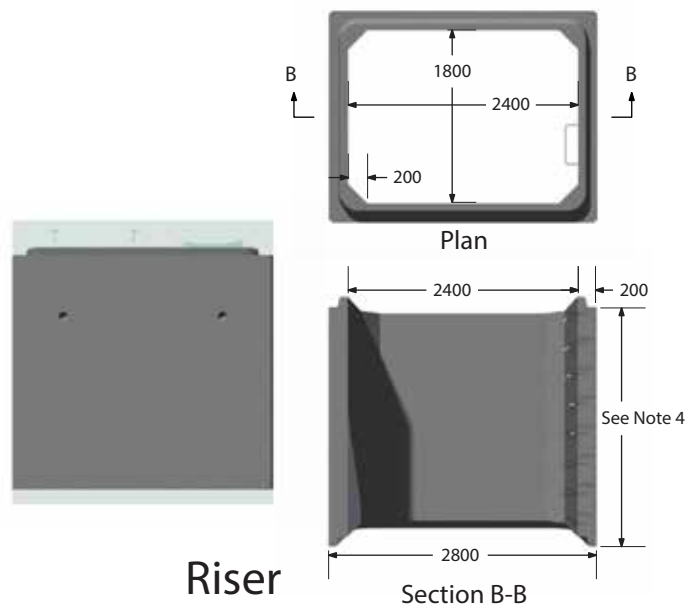

Riser
 (mass - 4821 kg/m)

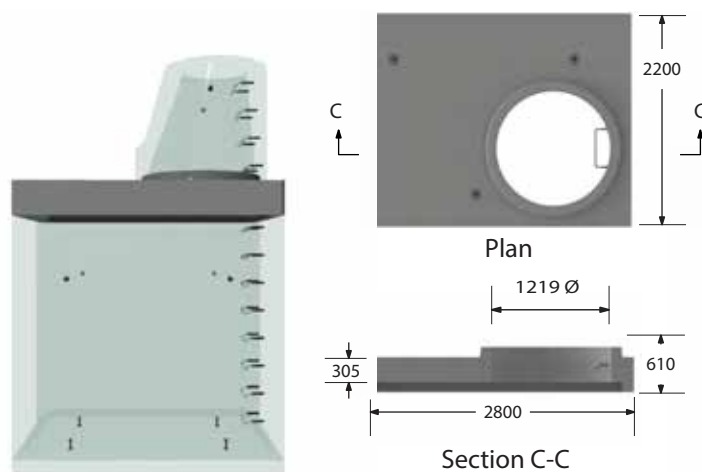

Transition
 (mass - 4000 kg)

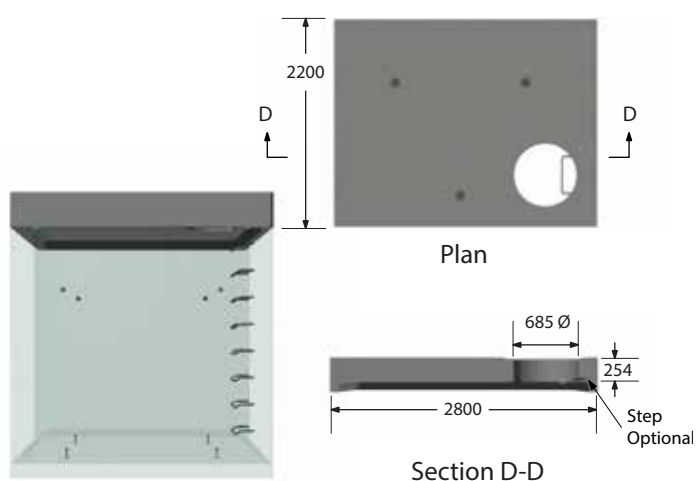

Flat Cap
 (mass - 4010 kg)

Drycast Maintenance Hole 2400 x 1800mm Box Chambers

Notes

1. Manufactured in accordance with CHBDC.
2. See page 57 for maximum pipe size and alignment angles.
3. Available riser section heights - 305, 610, 914, 1219, 1524, 1829, 2134 and 2500.
4. Maintenance hole steps (circular hollow aluminum) as per OPSD 405.010.
5. All dimensions are in millimeters unless otherwise shown.

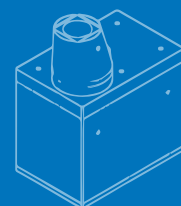



Plan

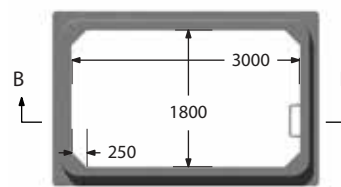

Plan

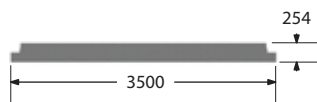

Section A-A

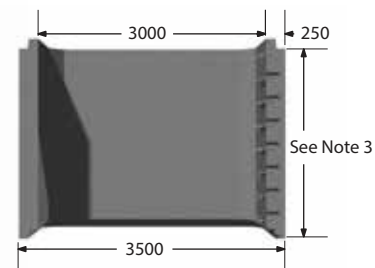

Section B-B

Base Slab

(mass - 4672 kg)

Riser

(mass - 6919 kg)



Plan



Plan

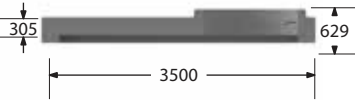

Section C-C

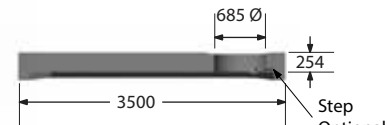

Section D-D

Transition

(mass - 5075 kg)

Flat Cap

(mass - 5350 kg)

Drycast Maintenance Hole 3000 x 1800mm Box Chambers

Notes

1. Manufactured in accordance with CHBDC.
2. See page 57 for maximum pipe size and alignment angles.
3. Available riser section heights - 305, 610, 914, 1219, 1524, 1829, 2134 and 2500.
4. Maintenance hole steps (circular hollow aluminum) as per OPSD 405.010.
5. All dimensions are in millimeters unless otherwise shown.

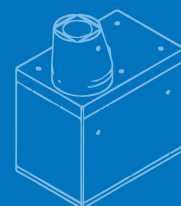

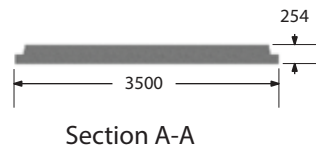

Base Slab

(mass - 5965 kg)

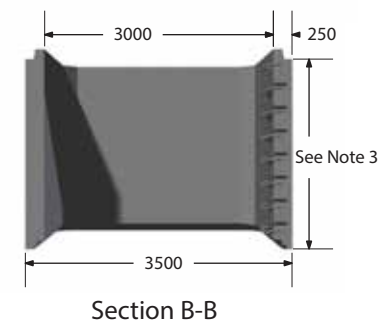
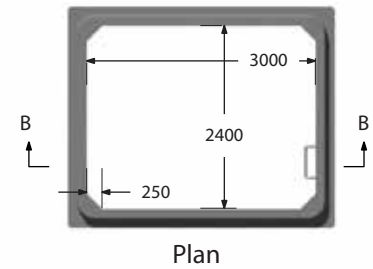

Riser

(mass - 2783 kg/m)

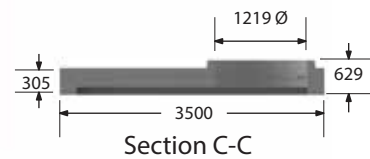

Transition

(mass - 6500 kg)

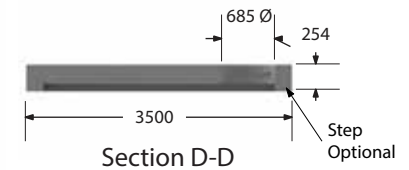
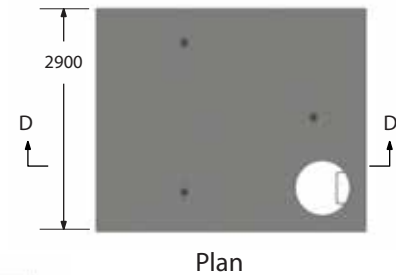

Flat Cap

(mass - 6720 kg)

Drycast Maintenance Hole 3000 x 2400mm Box Chambers

Notes

1. Manufactured in accordance with CHBDC.
2. See page 57 for maximum pipe size and alignment angles.
3. Available riser section heights - 305, 610, 914, 1219, 1524, 1829, 2134 and 2500.
4. Maintenance hole steps (circular hollow aluminum) as per OPSD 405.010.
5. All dimensions are in millimeters unless otherwise shown.

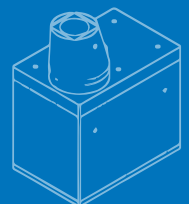

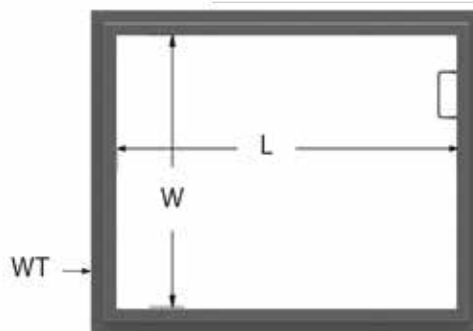

Length (L)	Width (W ₃)	Wall Thickness (WT ₂)
1829	914-1219	200
2438	1219-2438	200
2743	1219-2743	229/250/300/350
3048	1219-3048	229/300/350
3353	1219-3353	229/300/350
3658	1219-3658	229/300/350
3962	1219-3962	229/300/350
4267	1219-4267	229/300/350
4572	1219-4267	229/300/350
4877	1219-4267	229/300/350
5182	1219-4267	229/300/350
5486	1219-4267	229/254/305 depending on site conditions
5791	1219-4267	
6096	1219-4267	
6400	1219-4267	
6706	1219-4267	
7010	1219-4267	
7315	1219-4267	
7620	1219-4267	

Maintenance Hole Box Chambers

Notes

1. Designed in accordance with CSA S6 - CHBDC.
2. Chamber depth and connecting pipe size will determine chamber size and wall thickness.
3. See page 44 for 1200mm tapered top details.
4. Maintenance hole steps are circular hollow aluminum as per OPSD 405.010.
5. All dimensions are in millimeters unless otherwise shown.

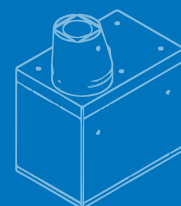



Ditch Inlet Type A

(mass - 1633 kg + 1830 kg/m)



Plan

Opening Dimensions			
Grate		a	b
Type	Slope		
B	2H:1V	670	52
	3H:1V	632	71
	4H:1V	618	78
	Horizontal	600	87

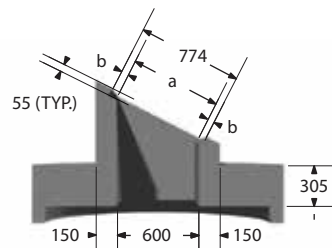

Section A-A

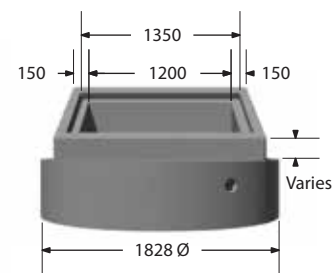

Font View



Ditch Inlet Type B

(mass - 1633 kg + 1830 kg/m)



Plan

Opening Dimensions				
Grate		a	b	C
Type	Slope			
C	2H:1V	1341	66	1473
	3H:1V	1265	104	1473
	4H:1V	1237	118	1473
B	6H:1V	1216	65	1346
	Horizontal	1200	73	1346

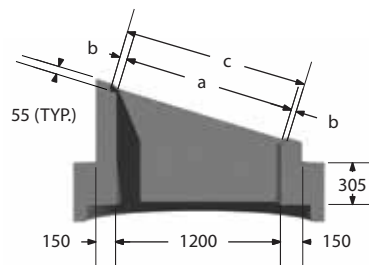

Section B-B

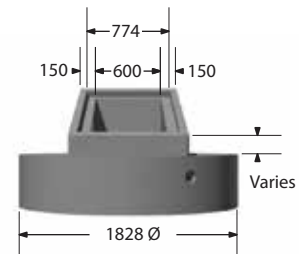

Font View

1500mm Flat Cap
 with 600 x 1200
 Ditch Inlet Top

Notes

1. Designed in accordance with OPSD 706.010 and OPSD 705.040 Type A and Type B.
2. For ditch inlet top information see page 88.
3. All dimensions are in millimeters unless otherwise shown.





Ditch Inlet Type A

(mass - 2704 kg + 1830 kg/m)



Plan

Opening Dimensions			
Grate		a	b
Type	Slope		
B	2H:1V	670	52
	3H:1V	632	71
	4H:1V	618	78
	Horizontal	600	87

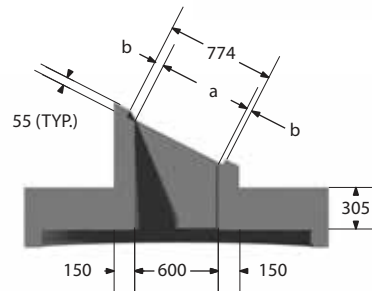

Section A-A

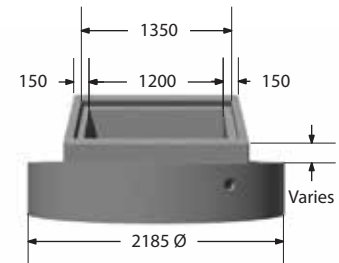

Font View



Ditch Inlet Type B

(mass - 2704 kg + 1830 kg/m)



Plan

Opening Dimensions				
Grate		a	b	C
Type	Slope			
C	2H:1V	1341	66	1473
	3H:1V	1265	104	1473
	4H:1V	1237	118	1473
B	6H:1V	1216	65	1346
	Horizontal	1200	73	1346

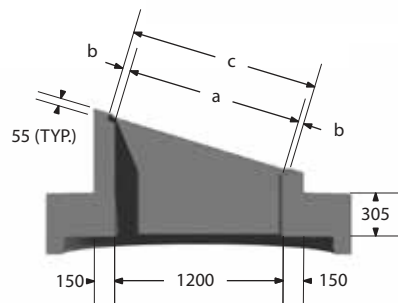

Section B-B

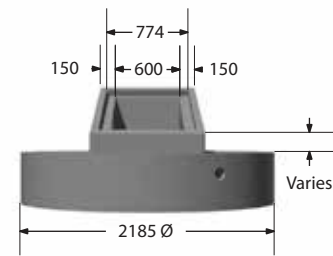

Font View

1800mm Flat Cap
 with 600 x 1200
 Ditch Inlet Top

Notes

1. Designed in accordance with OPSD 706.020 and OPSD 705.040 Type A and Type B.
2. For ditch inlet top information see page 88.
3. All dimensions are in millimeters unless otherwise shown.





Ditch Inlet Type A

(mass - 4930 kg + 1830 kg/m)

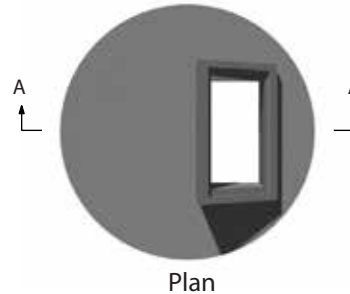

Plan

Opening Dimensions			
Grate			
Type	Slope	a	b
B	2H:1V	670	52
	3H:1V	632	71
	4H:1V	618	78
	Horizontal	600	87

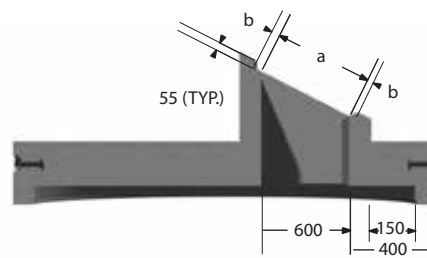

Section B-B

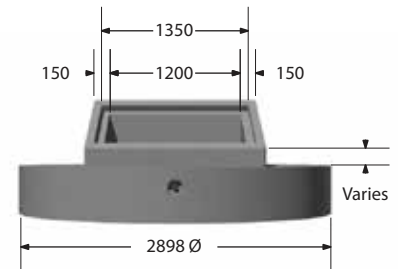

Front View



Ditch Inlet Type B

(mass - 4930 kg + 3660 kg/m)

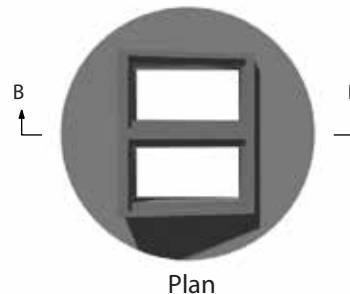

Plan

Opening Dimensions				
Grate				
Type	Slope	a	b	C
C	2H:1V	1341	66	1473
	3H:1V	1265	104	1473
	4H:1V	1237	118	1473
B	6H:1V	1216	65	1346
	Horizontal	1200	73	1346

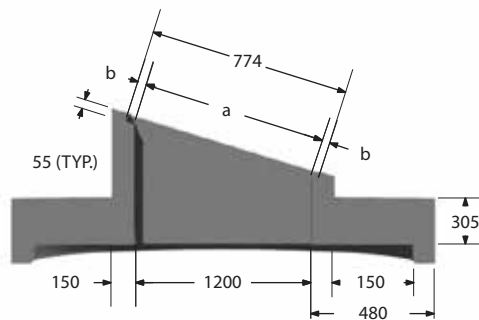

Section A-A

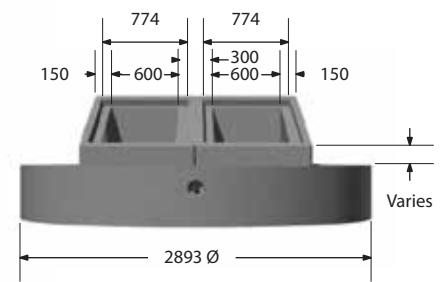

Front View

2400mm Flat Cap
 with 600 x 1200
 Ditch Inlet Top

Notes

1. Designed in accordance with OPSD 706.030, 706.031 and OPSD 705.040 Type A and Type B.
2. For ditch inlet top information see page 62.
3. All dimensions are in millimeters unless otherwise shown.





Ditch Inlet Type A

(mass - 4945 kg - 1830 kg/m)

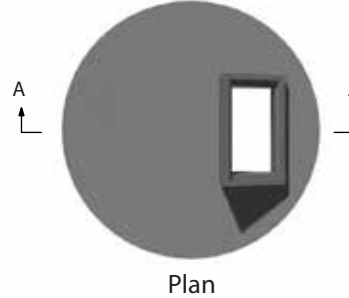

Plan

Opening Dimensions			
Grate		a	b
Type	Slope		
B	2H:1V	670	52
	3H:1V	632	71
	4H:1V	618	78
	Horizontal	600	87

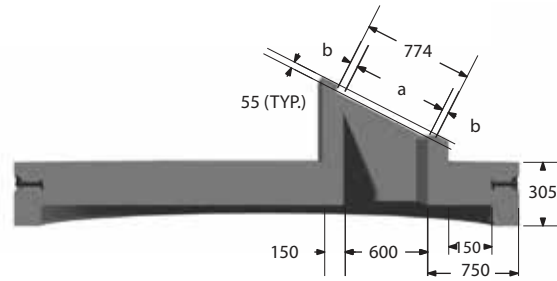

Section A-A

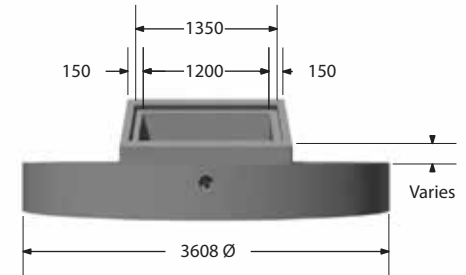

Front View



Ditch Inlet Type B

(mass - 7945 kg - 3660 kg/m)

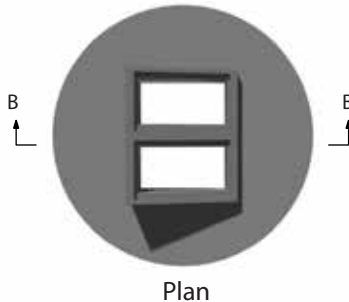

Plan

Opening Dimensions				
Grate		a	b	C
Type	Slope			
C	2H:1V	1341	66	1473
	3H:1V	1265	104	1473
	4H:1V	1237	118	1473
B	6H:1V	1216	65	1346
	Horizontal	1200	73	1346

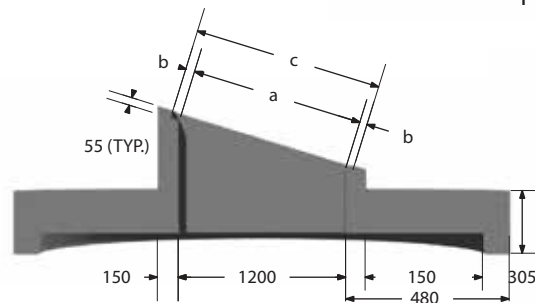

Section B-B

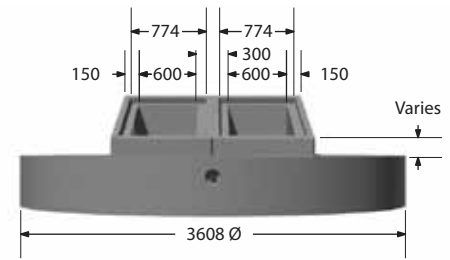

Front View

3000mm Flat Cap
 with 600 x 1200
 Ditch Inlet Top

Notes

1. Designed in accordance with OPSD 706.040, 706.041 and OPSD 705.040 Type A and Type B.
2. For ditch inlet top information see page 62.
3. All dimensions are in millimeters unless otherwise shown.





Ditch Inlet Type A



Opening Dimensions			
Grate		a	b
Type	Slope		
B	2H:1V	670	52
	3H:1V	632	71
	4H:1V	618	78
	Horizontal	600	87



Ditch Inlet Type B



Opening Dimensions				
Grate		a	b	C
Type	Slope			
C	2H:1V	1341	66	1473
	3H:1V	1265	104	1473
	4H:1V	1237	118	1473
B	6H:1V	1216	65	1346
	Horizontal	1200	73	1346



3600mm Flat Cap
 with 600 x 1200
 Ditch Inlet Top

Notes

1. Designed in accordance with OPSD 706.040, 706.041 and OPSD 705.040 Type A and Type B.
2. For ditch inlet top information see page 62.
3. All dimensions are in millimeters unless otherwise shown.



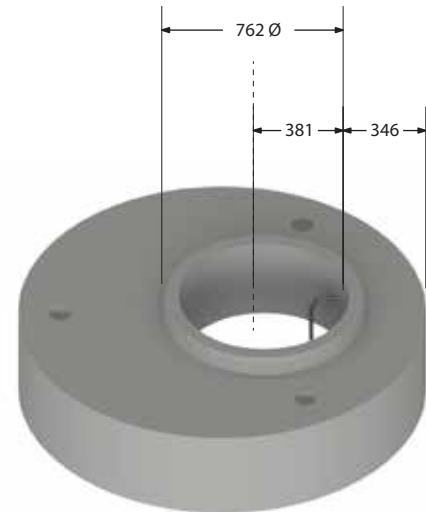
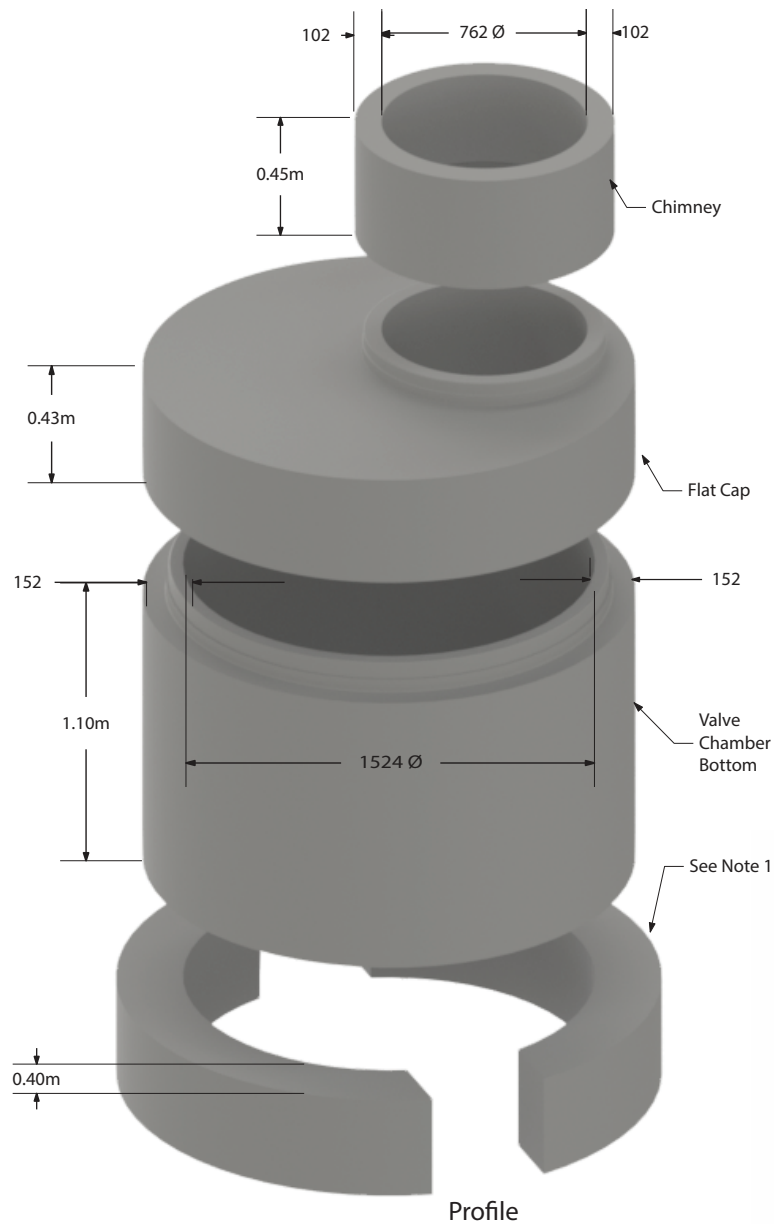

Flat Cap for
Gate Valve Opening

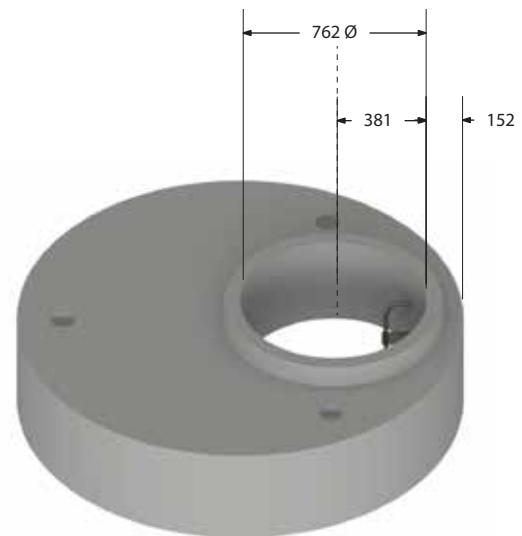

Flat Cap for
Butterfly Opening

City of Ottawa 1500mm Valve Chamber

Notes

1. Valve Chamber Base Sets as per City of Ottawa Standard W-5 See page 68.
2. Manufactured in accordance with OPSD 701.011 as well as City of Ottawa Standard W-2 (Butterfly VC) & W-3 (Gate VC).
3. 762mm \varnothing chimney manufactured in accordance with City of Ottawa Standard W-9.
4. All Valve Chambers c/w Hollow Aluminum Steps as per OPSD 405.010.
5. For adjusters refer to drawing page 122.



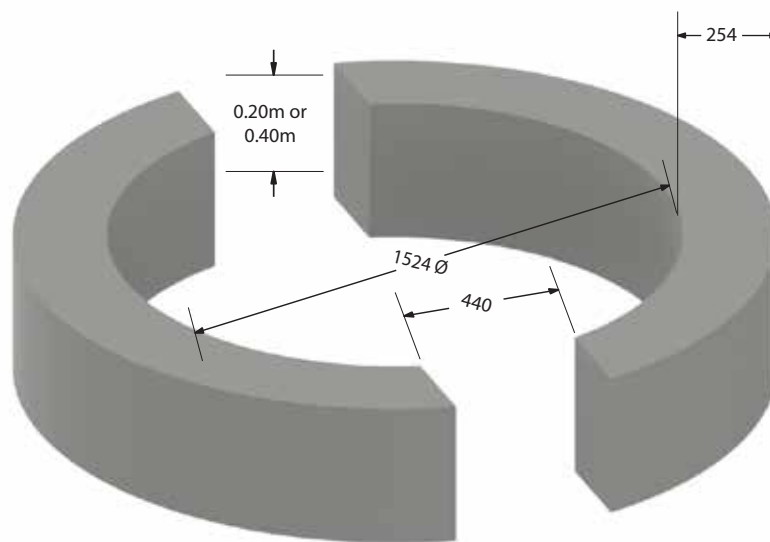

City of Ottawa Valve Chamber Base Sets

Notes

1. Manufactured in accordance with City of Ottawa drawing W-5.
2. All pieces c/w lifting anchors.
3. For 300Ø and 400Ø Watermain, stack base sets two sets high.

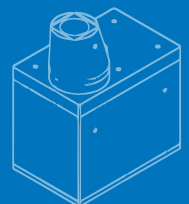

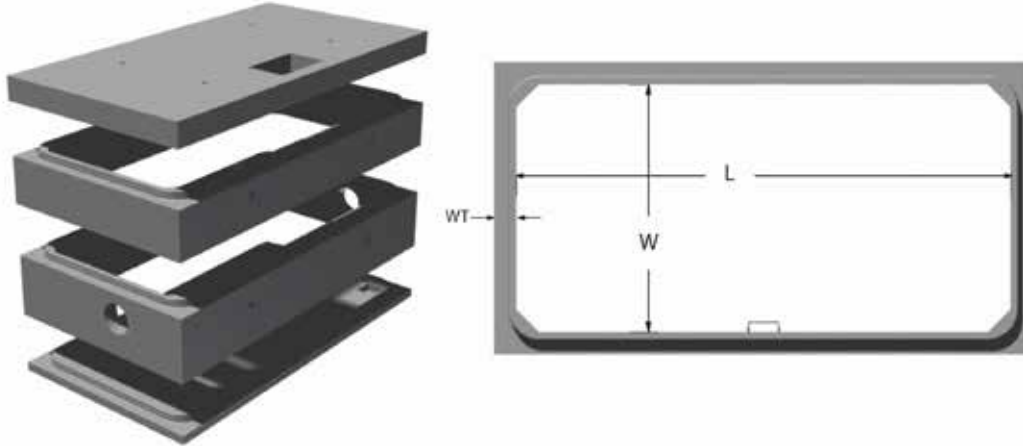

Length (L)	Width (W ₃)	Wall Thickness (WT ₂)
1829	914-1219	200
2438	1219-2438	200
2743	1219-2743	229/250/300/350
3048	1219-3048	229/300/350
3353	1219-3353	229/300/350
3658	1219-3658	229/300/350
3962	1219-3962	229/300/350
4267	1219-4267	229/300/350
4572	1219-4267	229/300/350
4877	1219-4267	229/300/350
5182	1219-4267	229/300/350
5486	1219-4267	229/254/305 depending on site conditions
5791	1219-4267	
6096	1219-4267	
6400	1219-4267	
6706	1219-4267	
7010	1219-4267	
7315	1219-4267	
7620	1219-4267	

Maintenance, Valve & Meter Box Chambers

Notes

1. Designed in accordance with CSA S6 - CHBDC.
2. Chamber depth and connecting pipe size will determine chamber size and wall thickness.
3. Maintenance hole steps are circular hollow aluminum as per OPSD 405.010.
4. All dimensions are in millimeters unless otherwise shown.



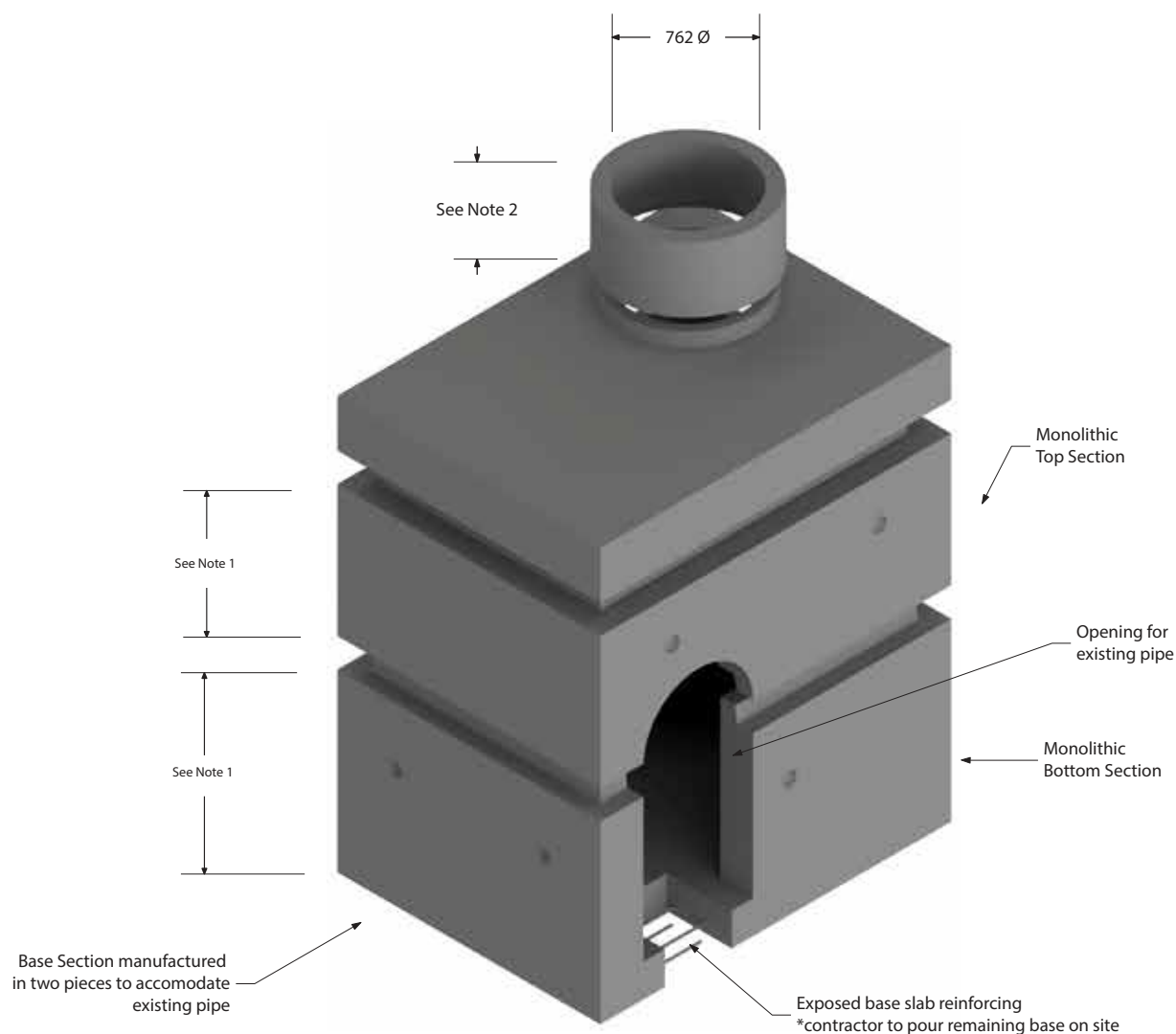

City of Ottawa T.V.S. Valve Chamber

Notes

1. Manufactured in accordance with City of Ottawa specification W-11.1.
2. All Valve Chambers c/w Hollow Aluminum Steps as per OPSD 405.010.
3. For adjusters refer to drawing page 122.
4. All heights as per City of Ottawa standards.
5. 762Ø chimney height as required.
6. For available Valve Chamber sizes see page 67-69.
7. Mono top sections available if required.

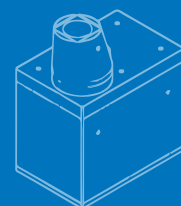

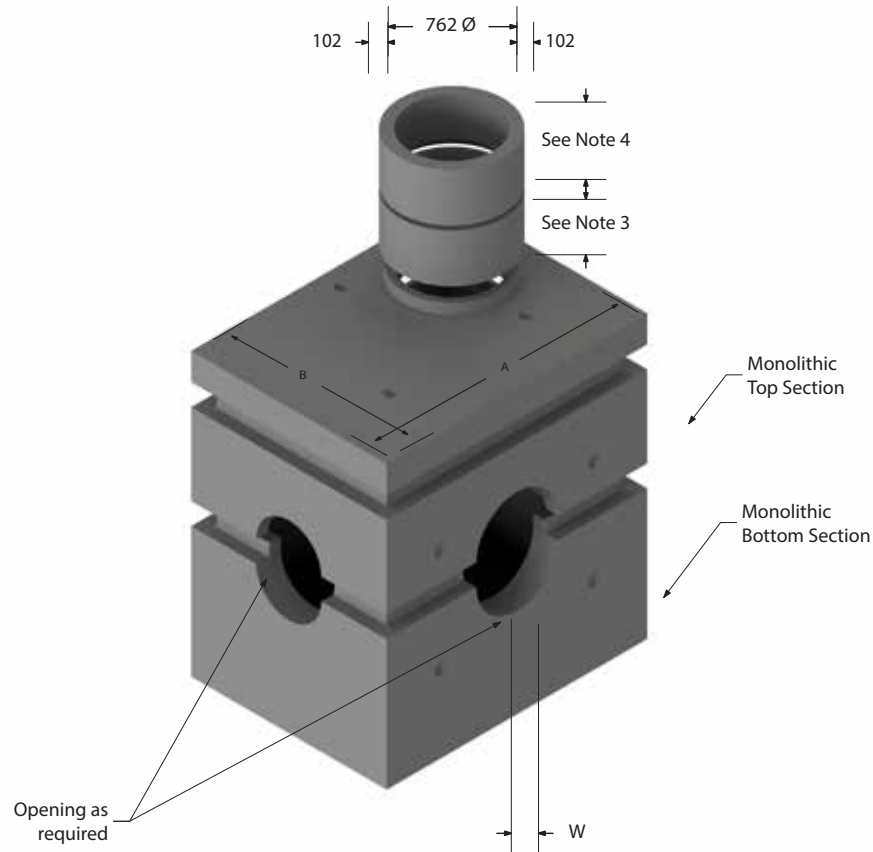

City of Ottawa Specification	Inside Dimensions	Outside Dimensions		Top Slap Thickness	Bott. Slap Thickness	Wall (W) Thickness
		A	B			
W31.1	1524 x 1829	1982	2287	229	229	229
W10 ~ R1	1829 x 2438	2134	2896	229	229	229
W10 ~ R2	1829 x 3048	2134	3506	229	229	229
W11 ~ R3	2438 x 3048	2896	3506	254	254	229
W11 ~ R4	3048 x 3810	3506	4268	254	254	229
W12 ~ R3	2438 x 3048	2896	3506	254	254	229
W12 ~ R4	3048 x 3810	3506	4268	254	254	229
W13 ~ R4	3048 x 3810	3506	4268	254	254	229

City of Ottawa Box Valve Chamber

Notes

1. Manufactured in accordance with City of Ottawa Standards.
2. All Valve Chambers c/w Hollow Aluminum Steps as per OPSD 405.010.
3. All pieces c/w lifting anchors.
4. Pipe gaskets available upon request.
5. All joints to be sealed with Hydrophilic Waterstop & a Waterproofing membrane.
6. For adjusters refer to drawing page 122.
7. Mono top sections available if required.



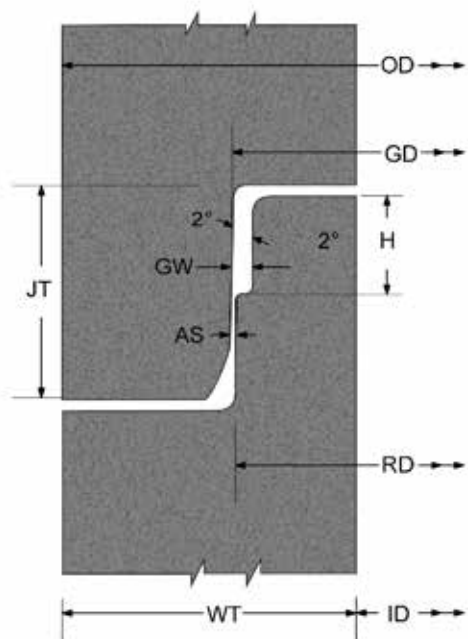

ID (Nominal)	ID (Actual)	OD	WT	JT	RD	GD	AS	GW	H
1200	1220	1474.0	127.0	107.9	1325.1	1343.3	3.7	11.3	63.5
1500	1524	1828.0	152.0	120.6	1635.2	1653.4	3.7	11.3	66.8
1800	1829	2185.0	178.0	127.0	1959.8	1978.0	3.7	11.3	66.8
2400	2438	2895.6	228.6	127.0	2619.0	2640.8	4.4	13.3	69.9
3000	3048	3606.8	279.4	152.4	3247.7	3269.5	4.4	13.3	69.9
3600	3658	4356	350.0	152.4	3895.4	3917.2	3.7	12.7	50.8

Maintenance Hole Joint Detail 1200-3600mm

Notes

1. Pre-lubricated rubber gaskets to be used with this maintenance hole joint Gaskets design.
2. All dimensions are in millimeters unless otherwise shown.

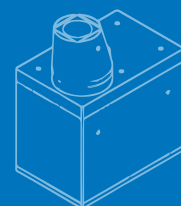

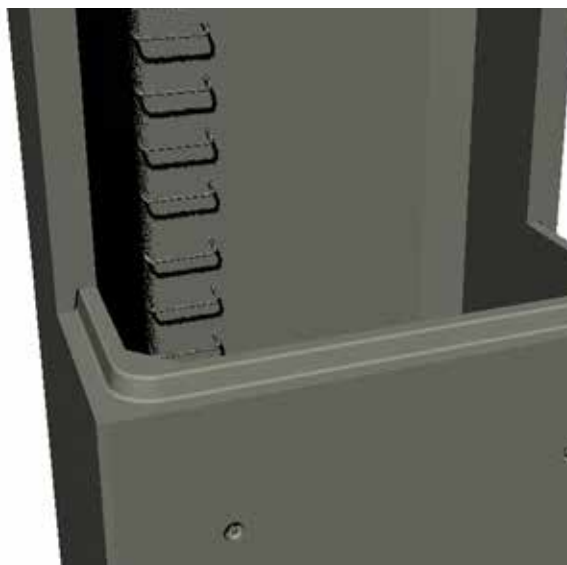
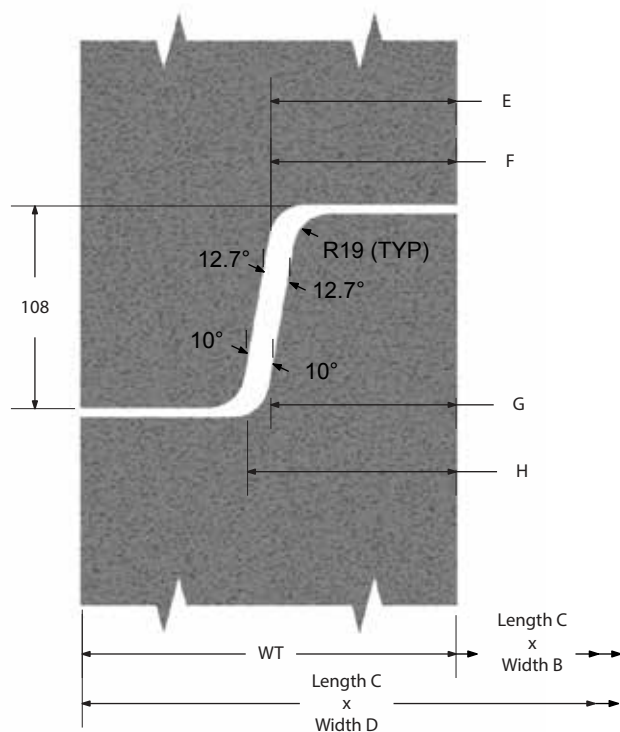

Inside		Outside		E	F	G	H	WT	JT
Length A	Width B	Length C	Width D						
1800	1200	2200	1600	96.9	84	103.1	116	200	108
2400	1800	2800	2200	96.9	84	103.1	116	200	180
3000	1800	3500	1700					250	127
3000	2400	3500	2900					250	127

Maintenance Hole Box Chambers Standard Wall

Notes

1. Continuous Butyl Gasket to be used with this Maintenance Hole Joint Design.
2. Dimensions are in millimeters unless otherwise shown.

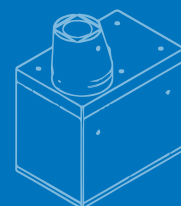

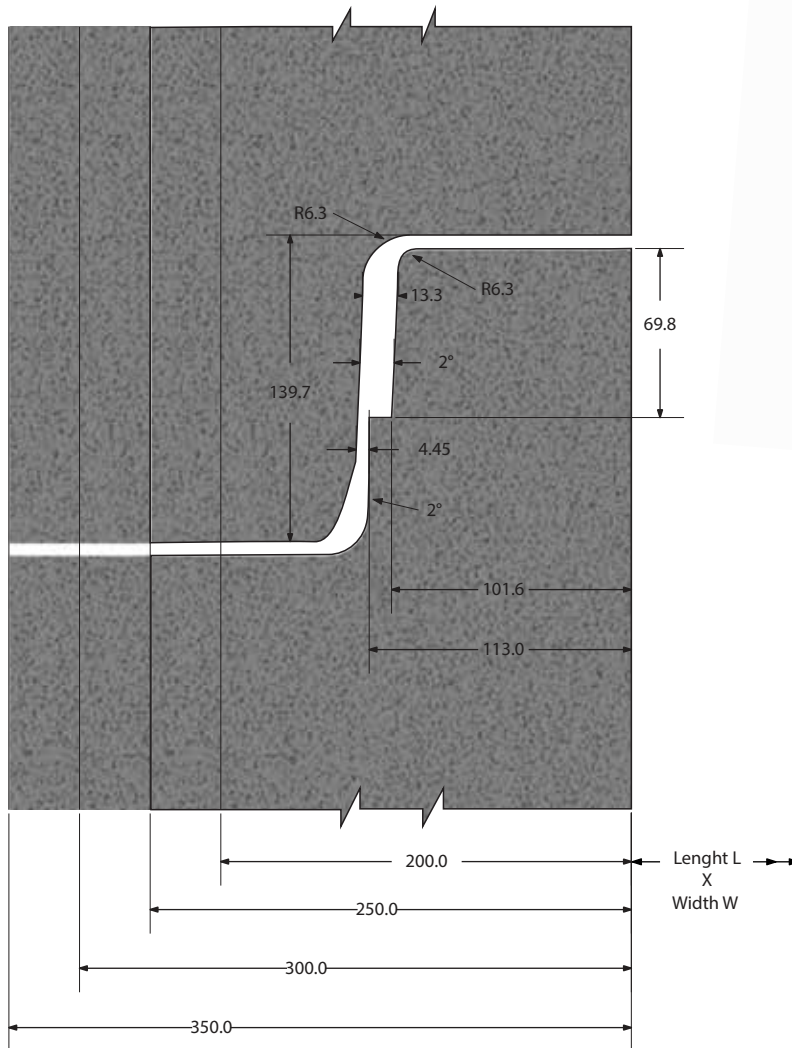

Length (A)	Width (B)
2438	1219-2438
2743	1219-2743
3048	1219-3048
3353	1219-3353
3658	1219-3658
3962	1219-3962
4267	1219-4267
4572	1219-4267
4877	1219-4267
5182	1219-4267
5486	1219-4267
5791	1219-4267
6096	1219-4267
6400	1219-4267
6706	1219-4267
7010	1219-4267
7315	1219-4267
7620	1219-4267

Maintenance Hole Box Chambers Variable Wall Thickness

Notes

1. Pre-lubricated continuous rubber gasket to be used with this joint design.
2. All dimensions are in millimeters unless otherwise shown.



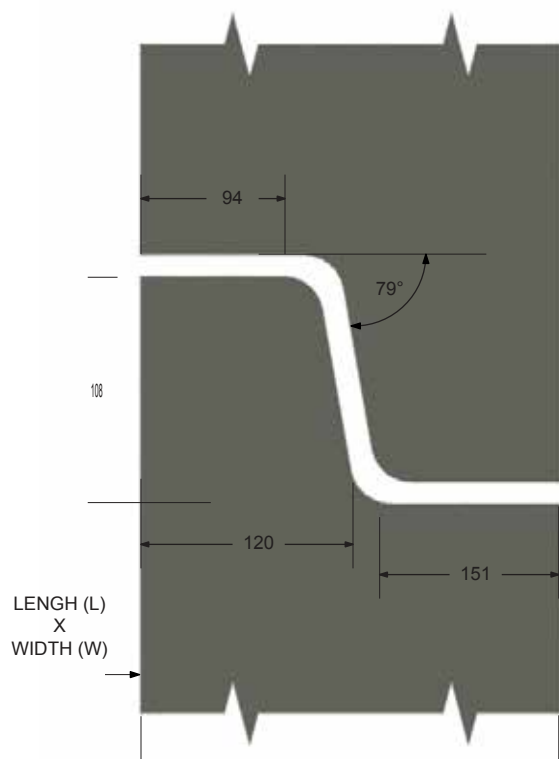

Box Name	Length L	Width W	Wall WT
M-3.3	914	914	152
M-4	1219	1219	229
M-5	1524	1829	229
M-5.5	1829	1829	229
M-6	1676	2438	229
M-6.5	1829	2438	229
M-7	1676	3048	229
M-7.5	1829	3048	229
M-8	2438	2438	229

Box Name	Length L	Width W	Wall WT
M-9	2438	3048	229
M-9.5	3048	3048	229
M-10	2438	3810	229
M-11	3048	3810	229
M-12	3810	3810	229
M-13	2438	4270	229
M-14	3048	4270	229
M-15	3810	4270	229
M-16	4270	4270	229

Maintenance Hole Ottawa Box Chambers Standard Wall

Notes

1. Butyl tape gasket to be used with this Maintenance joint design.
2. All dimensions are in millimeters unless otherwise shown.

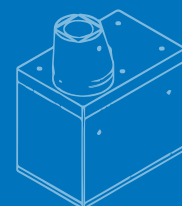

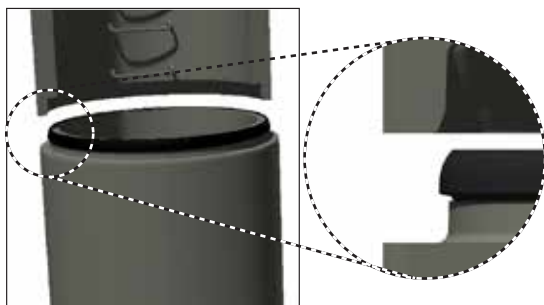

Step 1

Clean all dirt and foreign objects off the bell and spigot. Ensure both the bell and spigot are free of cracks, chips and defects.

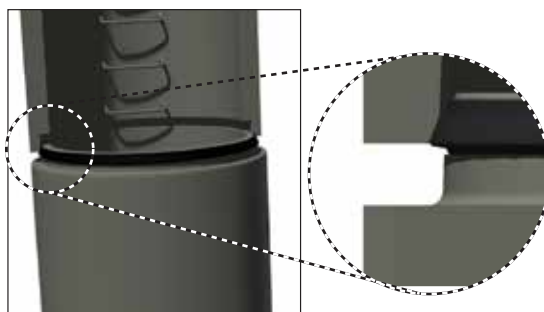

Step 2

Align the spigot with the bell. Ensure the gasket is in contact with the entire circumference of both the bell taper and the spigot before fully homing the joint.

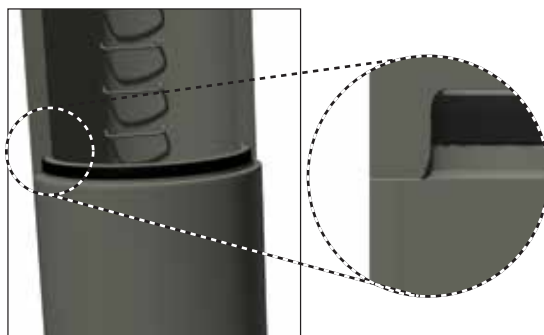

Step 3

Engage the spigot into the bell to fully install, locking the joint into place. The self lubricating gasket will roll over the step of the spigot and into the joint recess creating the complete seal.

Circular Maintenance Hole Jointing Procedure

Notes

1. The following above jointing procedure will ensure full optimization of pipe joint performance.

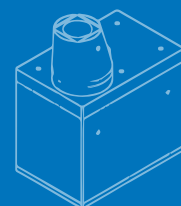

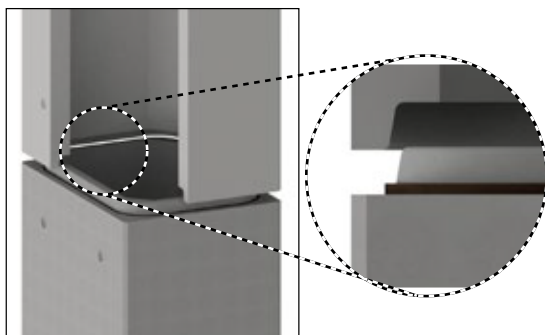

Step 1

Clean all dirt and foreign objects off the bell and spigot. Ensure both the bell and spigot are free of cracks, chips and defects. Apply butyl tape around the perimeter of the spigot.

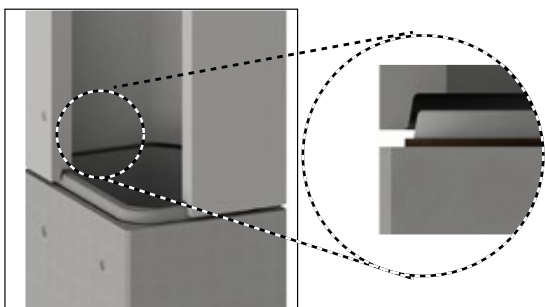

Step 2

Align the spigot with the bell. Ensure the butyl tape is in contact with the entire circumference of both the bell taper and the spigot before fully homing the joint.

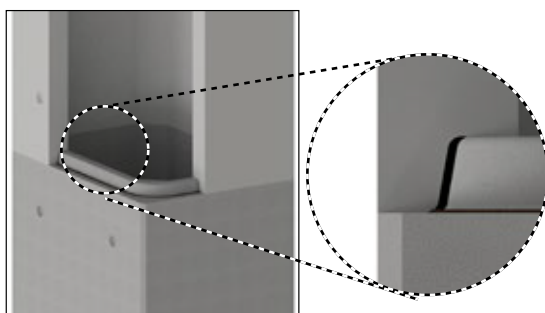

Step 3

Engage the spigot into the bell to fully install, locking the joint into place. The butyl tape will deform between the bell and spigot creating the complete seal.

Box Chamber Jointing Procedure

Notes

1. The following above jointing procedure will ensure full optimization of pipe joint performance.



SECTION 4 STORMWATER RETENTION SYSTEM

M CON
PRODUCTS



M CON
PRODUCTS

M CON Products
2150 Richardson Side Road
Ottawa, ON, K0A 1L0, Canada
t. + 1 800 267 5515
e. sales@mconproducts.com



Triple Box Culvert SWRS



Twin Box Culvert SWRS

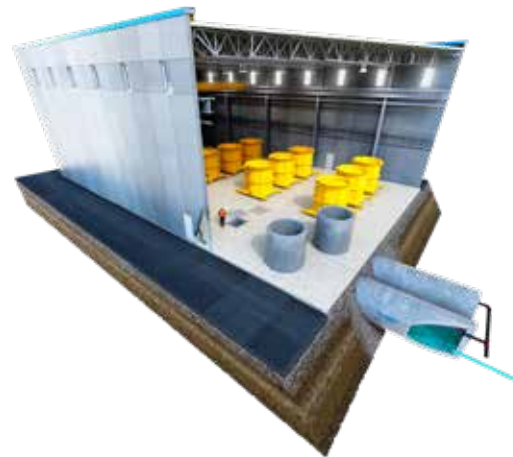

Twin Round SWRS

Stormwater Retention System

Notes

1. Size of tank components and number of cells will be determined by required storage volume and site constraints.





M CON Products
2150 Richardson Side Road
Ottawa, ON, K0A 1L0, Canada
t. + 1 800 267 5515
e. sales@mconproducts.com



Round SWRS -
Maintenance Holes

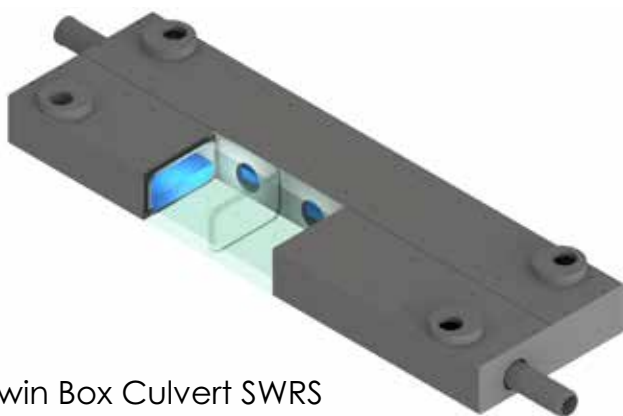

Twin Box Culvert SWRS

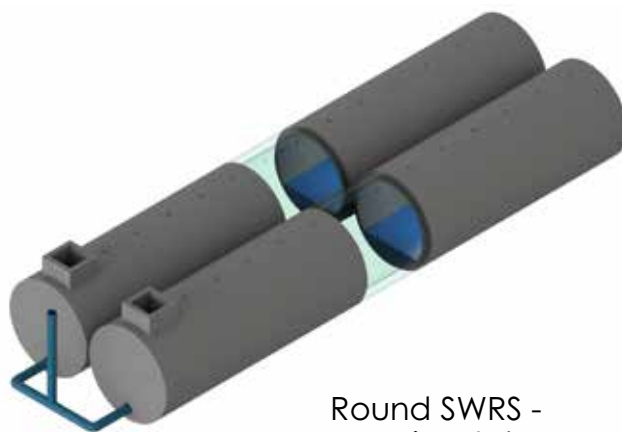

Round SWRS -
Horizontal

Stormwater Retention System

Notes

- 1. Size of tank components and number of cells will be determined by required storage volume and site constraints.



SECTION 5 OGS UNITS



M CON

PRODUCTS

M CON Products
 2150 Richardson Side Road
 Ottawa, ON, K0A 1L0, Canada
 tf. + 1 800 267 5515
 e. sales@mconproducts.com

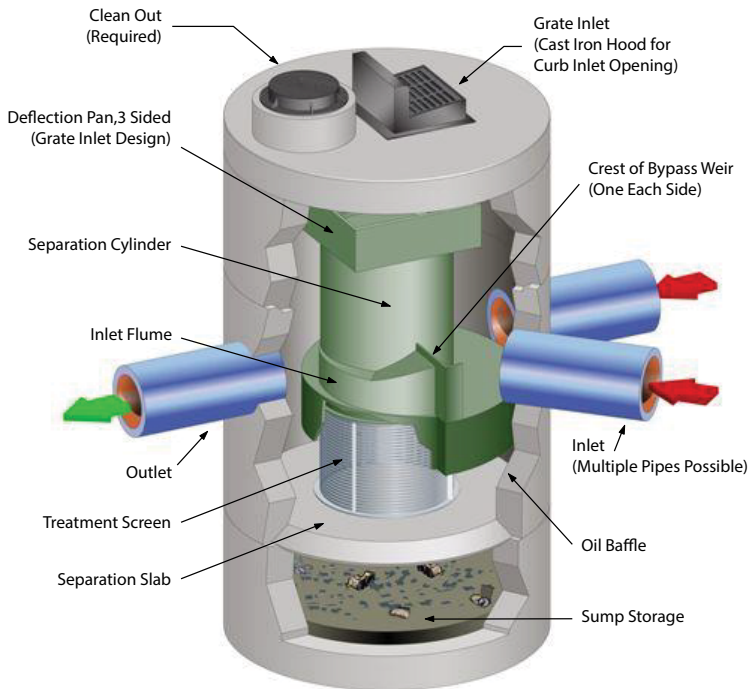

	CDS Model	Typical MH Dia. (ID)	Rated Treatment Flowrate (L/s)
20-Series	CDS2015-4	1200	20
	CDS2015-5	1500	20
	CDS2020-5	1500	31
	CDS2025-5	1500	45
30-Series	CDS3020-6	1800	57
	CDS3025-6	1800	68
	CDS3030-6	1800	85
	CDS3035-6	1800	106
40-Series	CDS4030-8	2400	127
	CDS4040-8	2400	170
	CDS4045-8	2400	212
56-Series	CDS5640-10	3000	255
	CDS5653-10	3000	396
	CDS5668-10	3000	538
	CDS5678-10	3000	708

OGS / Echelon

Notes

1. Can accommodate multiple inlets.
2. For custom sizes and design option, please contact Echelon Environmental at info@echelonenvironmental.ca.
3. Ontario Provincial Standards (OPS) – Approved for roadway applications.

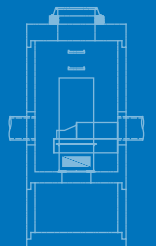

SECTION 6 CATCH BASINS

M CON
PRODUCTS



M CON Products
 2150 Richardson Side Road
 Ottawa, ON, K0A 1L0, Canada
 tf. + 1 800 267 5515
 e. sales@mconproducts.com



TABLE OF CONTENTS

SECTION 6 CATCH BASINS

600 x 600mm Single Inlet Catch Basin	85
600 x 1450mm Twin Inlet Catch Basin	86
600 x 1450mm Twin Inlet Catch Basin	87
600 x 600mm Ditch Inlet Catch Basin	88
600 x 1200mm Ditch Inlet Catch Basin	89
1200 x 1200mm Ditch Inlet Catch Basin - Type A	90
1200 x 1200mm Ditch Inlet Catch Basin - Type B	91
Sump Pit	92





M CON Products
 2150 Richardson Side Road
 Ottawa, ON, K0A 1L0, Canada
 tf. + 1 800 267 5515
 e. sales@mconproducts.com

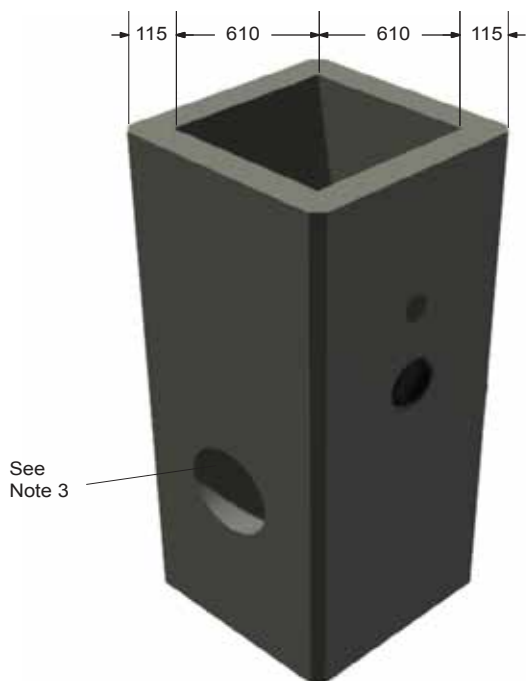

Standard CB

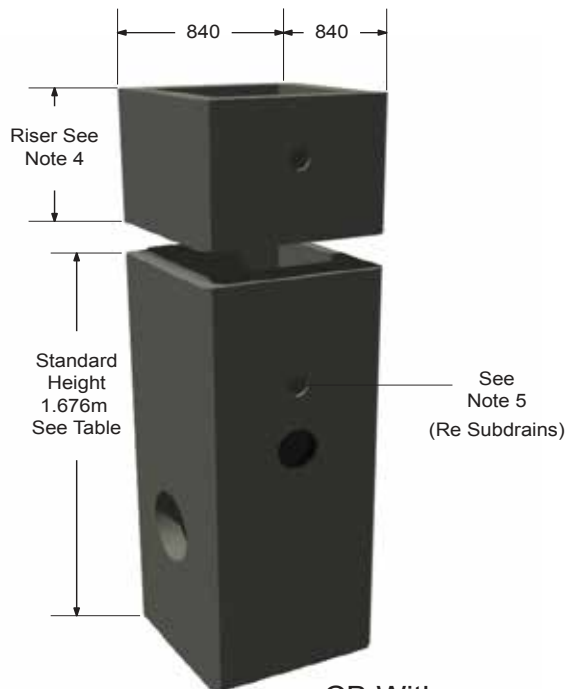

CB With Riser Section

Alternate Standard Heights (mm)	
A	1219
B	1372
C	1524
D	1676
E	1829
F	1981
G	2134

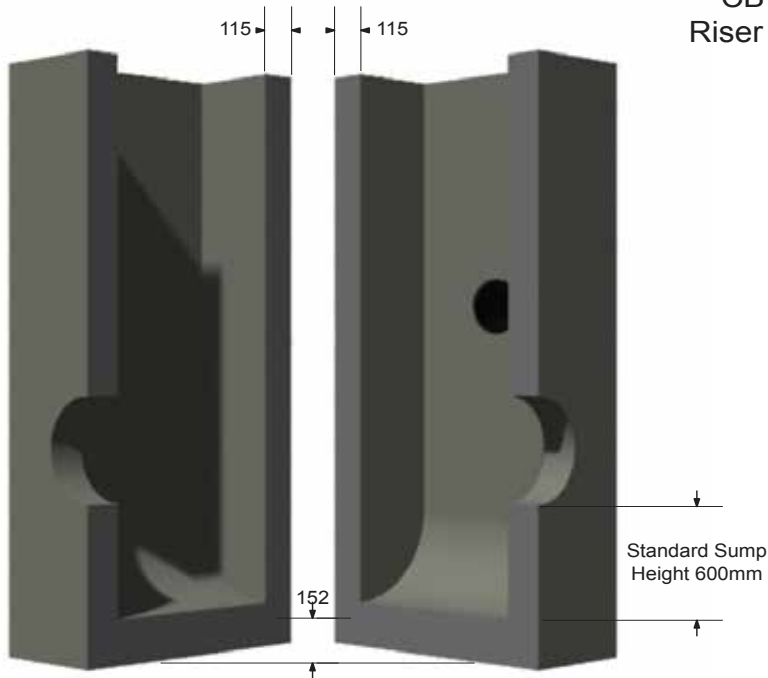

600 x 600mm Single Inlet Catch Basin

Notes

1. Manufactured in accordance with OPSD 705.010.
2. 150mm wall available upon request.
3. Standard opening size - 350mm diameter.
4. Riser sections available - 305, 457, 610, 914, and 1219mm
5. Subdrain connection insert for 100, 125, and 150mm diameter standard on all stock catch basins.
6. GOSS traps available upon request.
7. Flow restrictor plates available; IPEX/Plastech ICD.



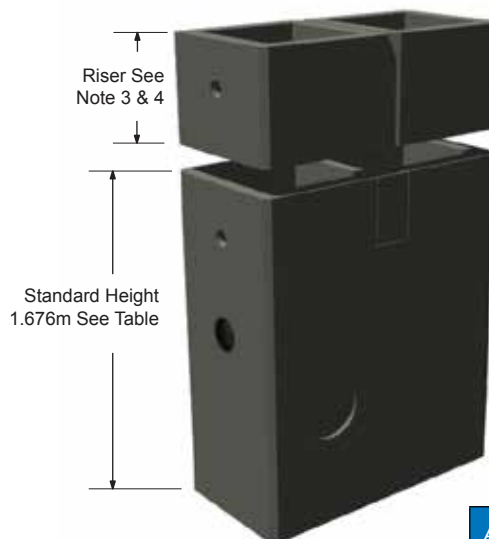
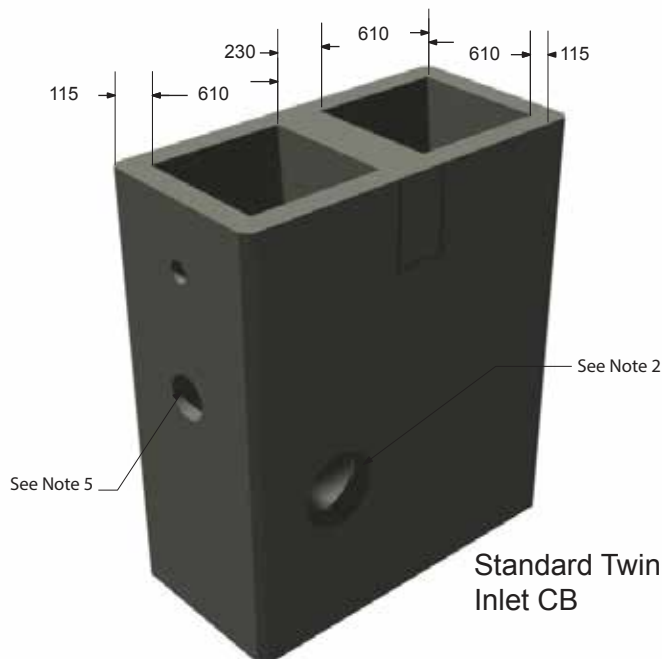

Alternate Standard Heights (mm)

A	1219
B	1372
C	1524
D	1676
E	1829
F	1981
G	2134

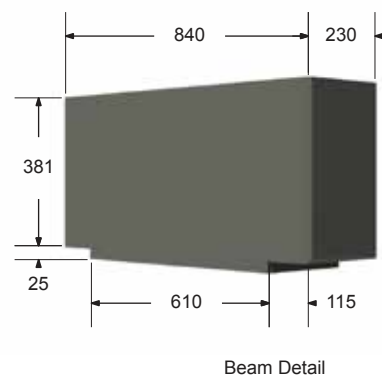
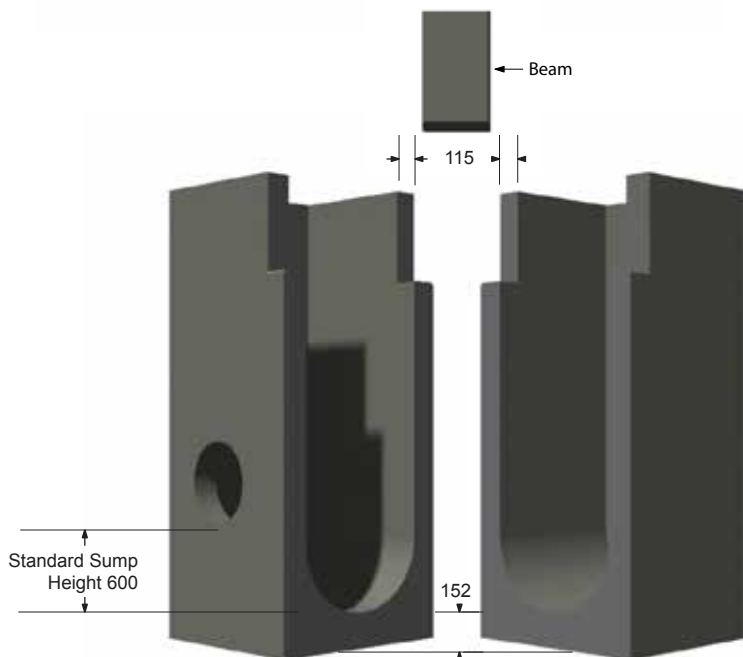

600 x 1450mm Twin Inlet Catch Basin

Notes

1. Manufactured in accordance with OPSD 705.020.
2. Standard opening size - 400mm diameter.
3. Vertical height may be increased by using two single catch basin riser sections. See page 71 for available riser sections.
4. Riser sections available - 305, 457, 610, 914, and 1219mm.
5. Subdrain connection insert for 100, 125, and 150mm diameter standard on all stock twin inlet catch basins.
6. GOSS traps available upon request.
7. IPEX/Plastech ICD backplates available.



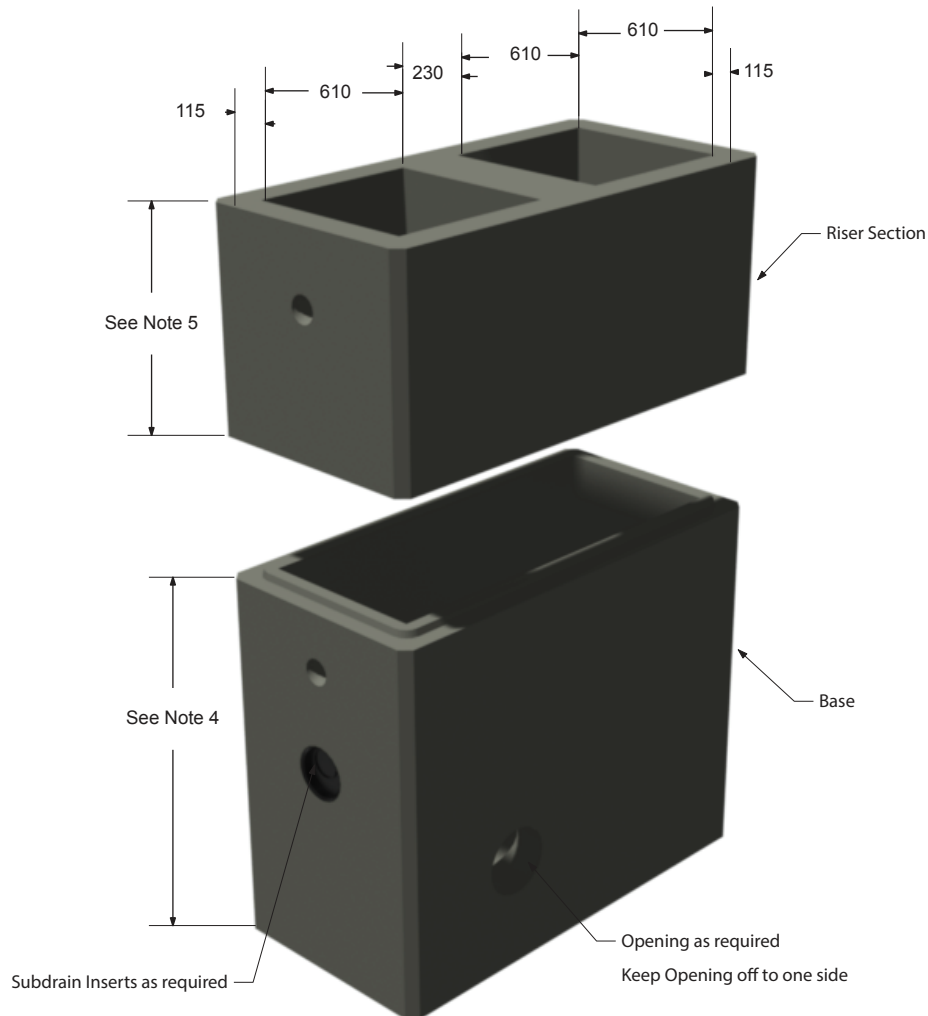

600 x 1450mm Twin Inlet Catch Basin

Notes

1. Manufactured in accordance with OPSD 705.020.
2. Standard sump of 600mm is provided.
3. Pipe gaskets available upon request.
4. Base heights as follows (Structures can be made in 1 piece):
.61m - 2.13m @ .15m increments.
5. Riser Section heights as follows: .76m - 1.68m @ .15m increment.
6. IPEX/Plastech ICD backplates available.



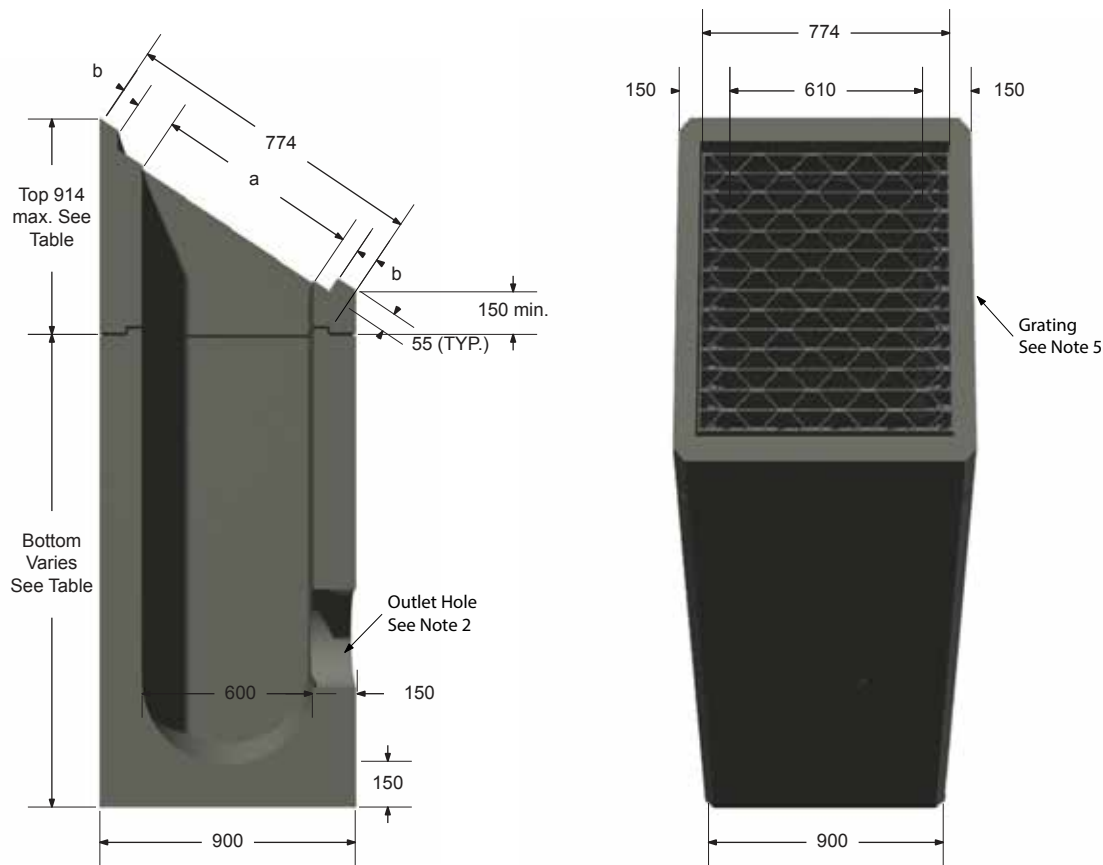

Opening Dimensions			
Grate		a	b
Type	Slope		
A	2H:1V	670	52
	3H:1V	632	71
	4H:1V	618	78
	6H:1V	608	83
	Horizontal	600	87

Standard Bottom Heights (mm)	
A	1219
B	1372
C	1524
D	1676
E	1829
F	1981
G	2130

Standard Top Heights (mm)	
A	305
B	457
C	610

600 x 600mm Ditch Inlet Catch Basin

Notes

1. Designed in accordance with OPSD 705.030.
2. Standard opening size - 400mm diameter.
3. Riser sections available - 305, 457, 610, 914, and 1219mm.
4. All dimensions are in millimeter unless otherwise shown.
5. Honey comb grating manufactured in accordance with OPSD 403.010 - Type A.
6. Refer to pages 54-57 to see how ditch inlets are incorporated into maintenance holes.
7. IPEX/Plastech ICD backplates available.





M CON Products
 2150 Richardson Side Road
 Ottawa, ON, K0A 1L0, Canada
 tf. + 1 800 267 5515
 e. sales@mconproducts.com

Ditch Inlet Type A

Opening Dimension			
Grate		a	b
Type	Slope		
B	2H:1V	670	52
	3H:1V	632	71
	4H:1V	618	78
	Horizontal	600	87

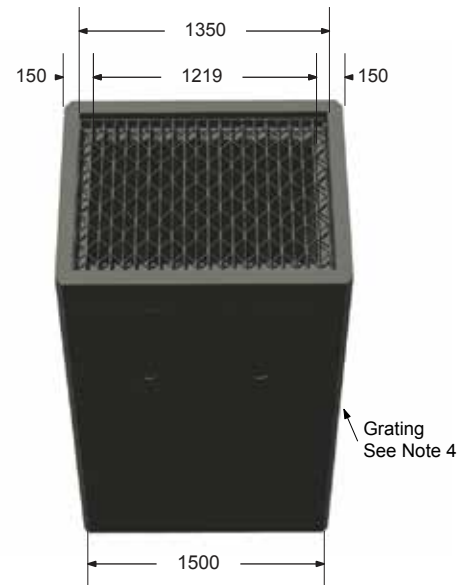
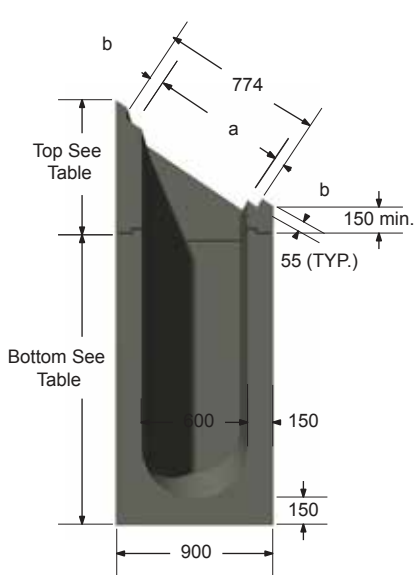

Ditch Inlet Type A

Ditch Inlet Type B

Opening Dimension				
Grate		a	b	c
Type	Slope			
C	2H:1V	1341	66	1473
	3H:1V	1265	104	1473
	4H:1V	1237	118	1473
B	6H:1V	1216	65	1346
	Horizontal	1200	73	1346

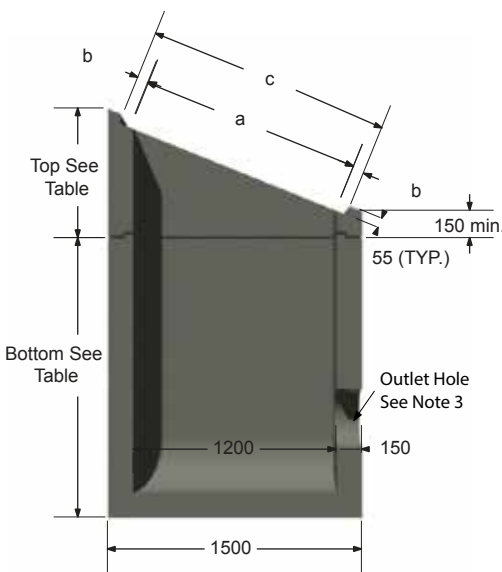

Ditch Inlet Type B

Standard Bottom Heights (mm)	
A	1219
B	1372
C	1524
D	1676
E	1829
F	1981

Standard Top Heights (mm)	
A	152
B	305
C	762
D	914

Notes
 A- Monolithic Base heights as follows: .61m - 1.53m @ .15m increments
 B- Riser Top Section heights as follows: .76m - 1.22m @ .15m increments
 C- Slopes available as follows: X = 2,3,4,6, & Horizontal

* Sections also available with variable heights @ .15m increments

600 x 1200mm Ditch Inlet Catch Basin

Notes

1. Manufactured in accordance with OPSD 705.040.
2. Riser sections are available in heights of .305 to 1.219m in 152mm increments.
3. Standard outlet opening is 50mm diameter.
4. Honey comb grating as per OPSD 403.010 - Type B and Type A.
5. All dimensions are in millimeters, unless otherwise shown.
6. Refer to pages 60-63 to see how ditch inlets are incorporated into maintenance holes.
7. IPEX/Plastech ICD backplates available.



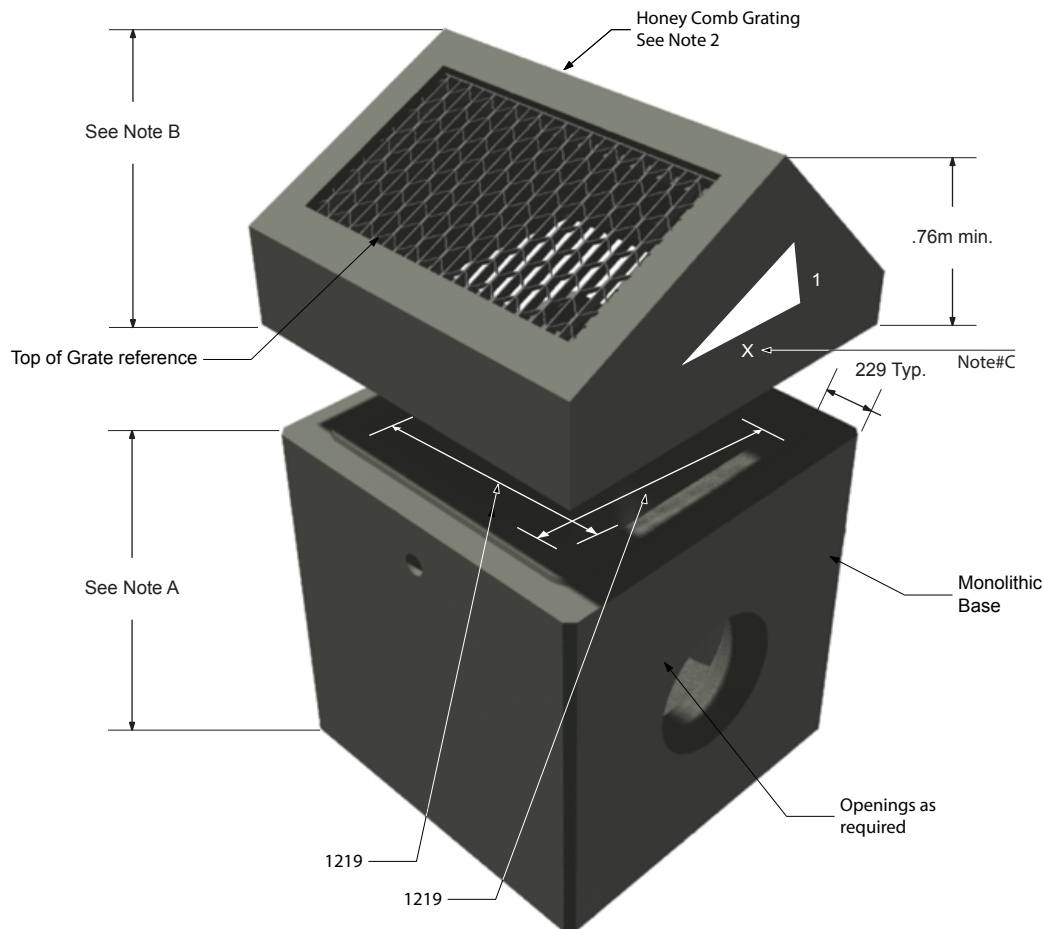

Notes

- A- Monolithic Base heights as follows: .61m - 1.53m @ .15m increments
 B- Riser Top Section heights as follows: .76m - 1.22m @ .15m increments
 C- Slopes available as follows: X = 2,3,4,6, & Horizontal

* Sections also available with variable heights @ .15m increments

1200 x 1200mm Ditch Inlet Catch Basin - Type A

Notes

1. Manufactured in accordance with OPSD 705.040.
2. Honey comb grating manufactured in accordance with OPSD 403.010 - Type "A."
3. All maintenance Holes c/w Hollow Aluminum Steps as per OPSD 405.010.
4. Standard sump of 300mm is provided.
5. Pipe gaskets available upon request.
6. Refer to pages 58-60 to see how ditch inlets are incorporated into maintenance holes.



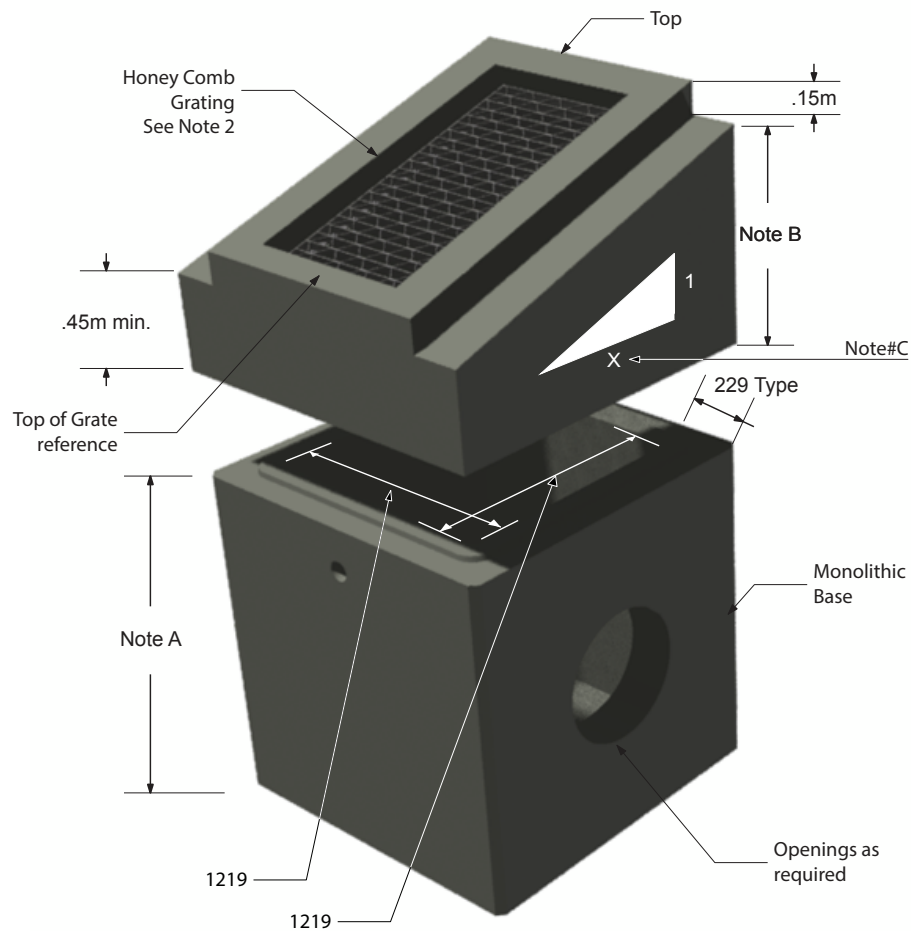

Notes

- A- Monolithic Base heights as follows: .61m - 1.53m @ .15m increments
 B- Riser Top Section heights as follows: .45m - 1.22m @ .15m increments
 C- Slopes available as follows: X = 2,3,4,6, & Horizontal

* Sections also available with variable heights @ .15m increments

1200 x 1200mm Ditch Inlet Catch Basin - Type B

Notes

1. Manufactured in accordance with OPSD 702.050.
2. Honey comb grating manufactured in accordance with OPSD 403.010 - Type "B" or Type "C."
3. All maintenance Holes c/w Hollow Aluminum Steps as per OPSD 405.010.
4. Standard sump of 300mm is provided.
5. Pipe gaskets available upon request.
6. Refer to pages 62-66 to see how ditch inlets are incorporated into maintenance holes.





M CON
PRODUCTS

M CON Products

2150 Richardson Side Road
Ottawa, ON, K0A 1L0, Canada
t. + 1 800 267 5515
e. sales@mconproducts.com

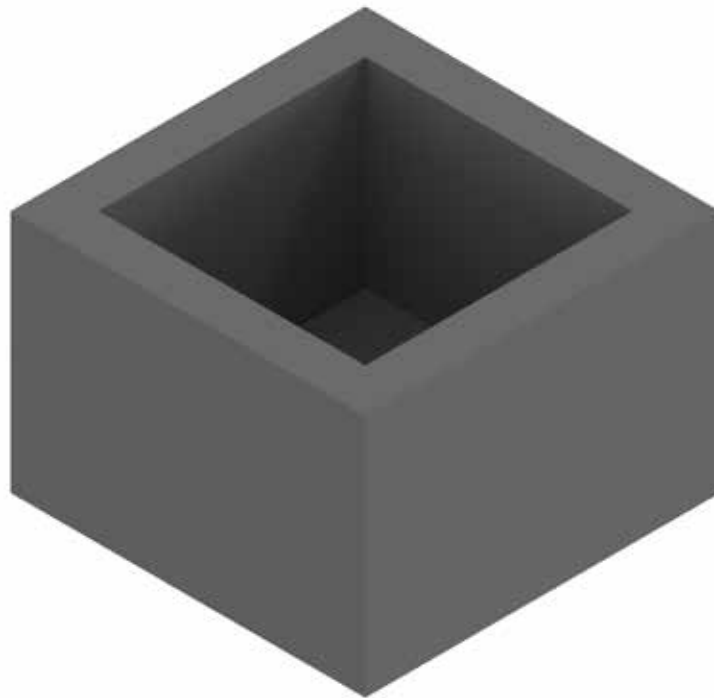

Box Name	Inside Dimensions	Outside Dimensions		Top Slap Thickness	Bott. Slap Thickness	Wall (W) Thickness
		A	B			
M-3-3	914 x 914	1218	1218	152	152	152
M-4	1219 x 1219	1677	1677	229	229	229

Sump Pit

Notes

1. Manufactured in accordance with OPSS 1351.
2. All dimensions are in millimeters unless otherwise shown.
3. Sump pits are manufactured with a flush top or exposed reinforcing from the top.
4. Alternate sizing available.



SECTION 7 HEADWALLS

M CON
PRODUCTS



M CON Products
2150 Richardson Side Road
Ottawa, ON, K0A 1L0, Canada
t. + 1 800 267 5515
e. sales@mconproducts.com

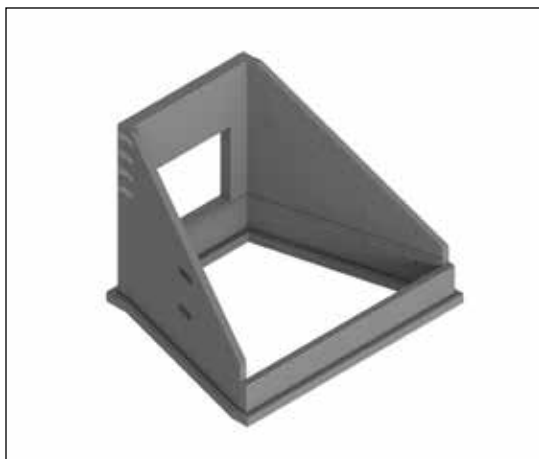

TABLE OF CONTENTS

SECTION 7 HEADWALLS

Headwall 300 to 900mm Pipe	95
Headwall 300 to 1500mm Pipe	96
Headwall 600 to 1800mm Pipe	97
Segmental Headwalls for 1950 to 3000mm Pipe.....	98





M CON

PRODUCTS

M CON Products
 2150 Richardson Side Road
 Ottawa, ON, K0A 1L0, Canada
 t. + 1 800 267 5515
 e. sales@mconproducts.com

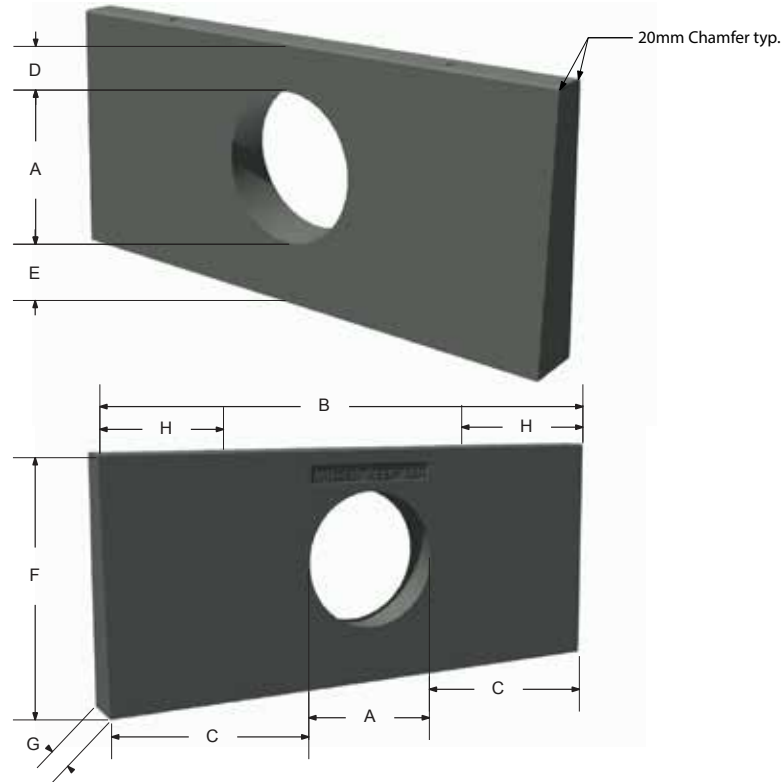

Pipe Size Conc.	Pipe Size Conc.	Opening	Width				Height	Bottom Thickness	Mass	Anchor	Anchor Size
Nom	O.D.	A	B	C	D	E	F	G	Kg	H	pcs
300	445	550	3366	1408	398	724	1672	439	5028	800	2 - 8 Ton
375	533	610	3366	1378	512	561	1672	439	4976	800	2 - 8 Ton
450	622	711	3366	1827	406	555	1672	439	4877	800	2 - 8 Ton
525	711	820	4168	1674	396	545	1939	462	7262	1000	2 - 8 Ton
600	800	910	4168	1629	395	545	1939	462	7143	1000	2 - 8 Ton
675	889	990	4168	1589	400	549	1939	462	7024	1000	2 - 8 Ton
750	978	1080	4968	1944	399	549	2206	484	9951	1000	2 - 8 Ton
825	1067	1170	4968	1899	390	548	2206	484	9789	1000	2 - 8 Ton
900	1156	1260	4968	1854	398	548	2206	484	9612	1000	2 - 8 Ton

Headwall 300 to 900mm Pipe

Notes

1. Precast alternative to OPSD 804.030.
2. Headwall grates are available upon request.
3. All dimensions are in milliliters unless otherwise shown.
4. Alternate openings are available upon request.

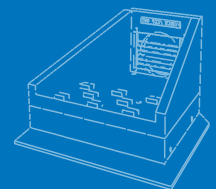



M CON
PRODUCTS

M CON Products
2150 Richardson Side Road
Ottawa, ON, K0A 1L0, Canada
t. + 1 800 267 5515
e. sales@mconproducts.com

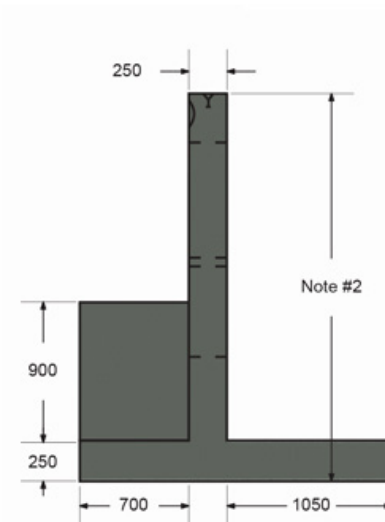
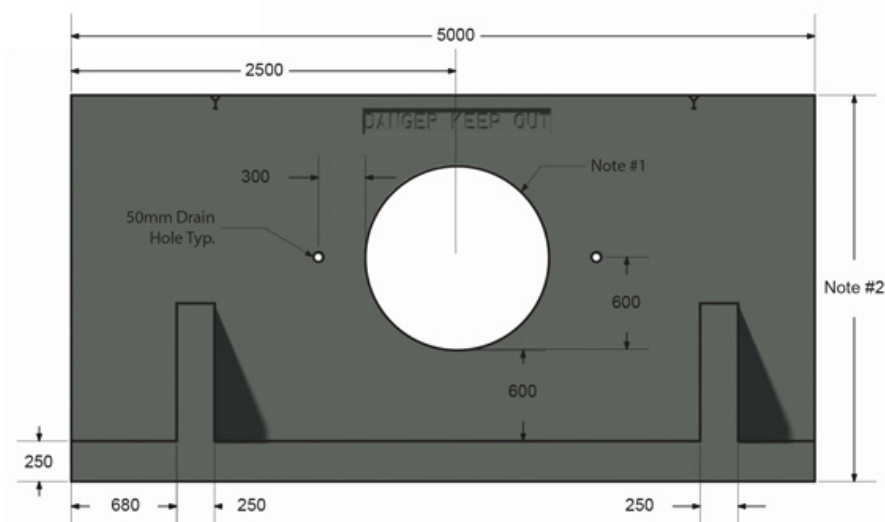
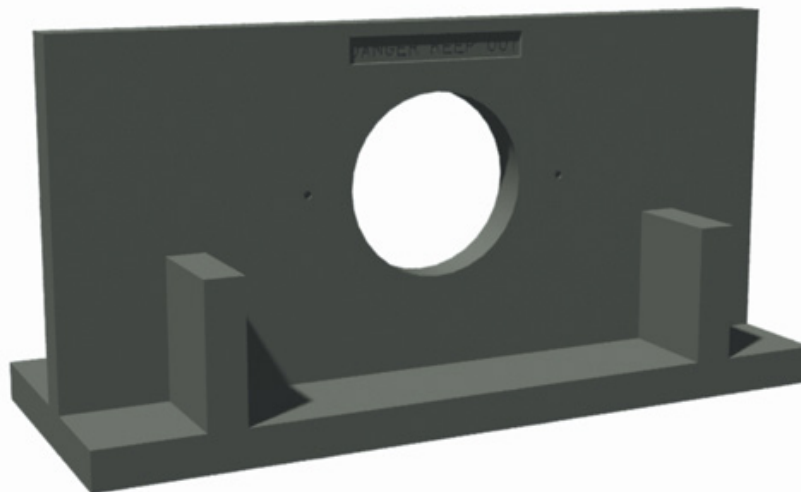

Headwall 300 to 1500mm Pipe

Notes

1. Precast alternative to OPSD 804.020.
2. Height of headwall will depend on the size of pipe.
3. Headwall grates as shown are available upon request.
4. Maximum weight = 15,000 kgs.
5. All dimensions are in millimeters unless otherwise shown.
6. Alternate openings are available upon request.

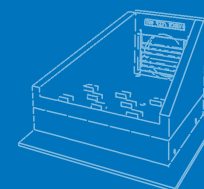

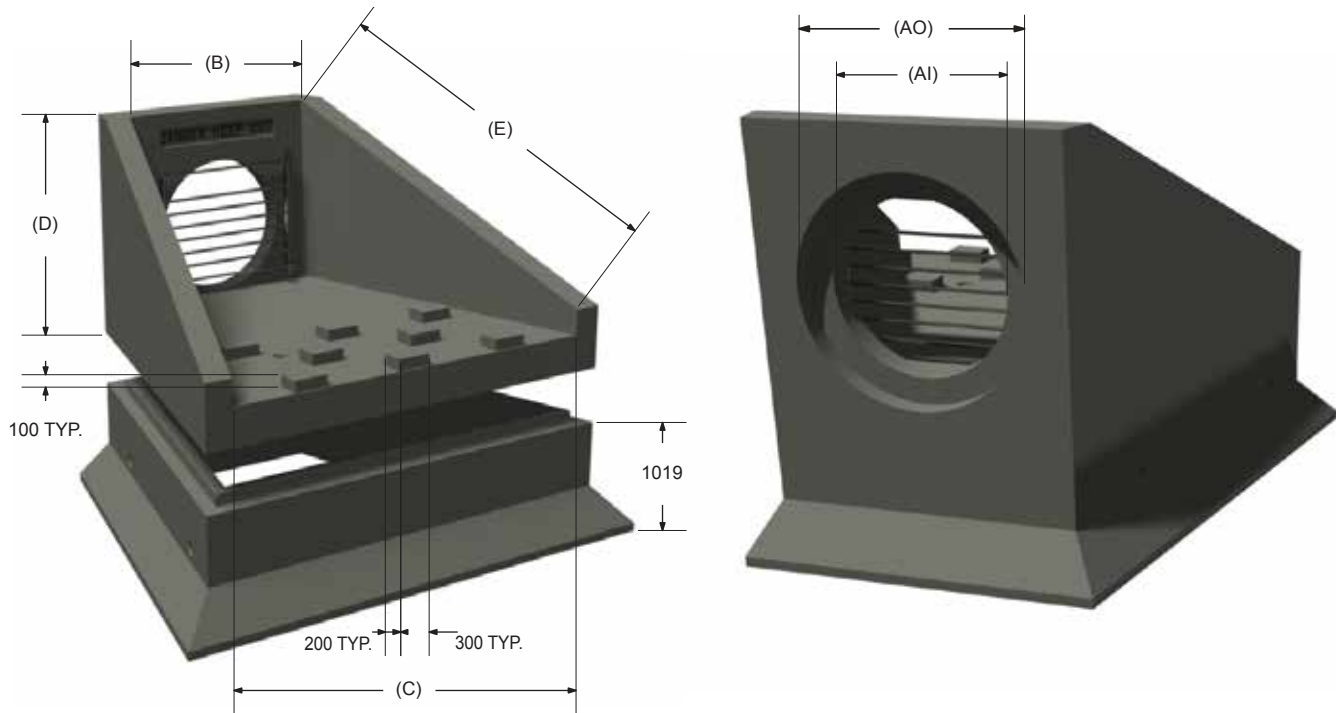

Pipe Size	Opening Front (Pipe I.D.)	Opening Back	Inside Wall (Back)	Inside Wall (Front)	PS-2 Height	PS-2 Length	Mass (Top)	Mass (Bottom)
Nom	Ai	Ao	B	C	D	E	kg	kg
600	610	880	1219	2532	1623	2750	7,733	7,434
675	686	960	1219	2532	1623	2750	7,654	7,434
750	762	1050	1219	2532	1623	2750	7,554	7,434
825	838	1140	1219	2532	1623	2750	7,452	7,434
900	914	1230	1829	3463	2039	3350	12,652	9,627
975	991	1320	1829	3463	2039	3350	12,526	9,627
1050	1067	1410	1829	3463	2039	3350	12,394	9,627
1200	1219	1590	1829	3463	2039	3350	12,103	9,627
1350	1372	1760	2438	4072	2709	3350	17,106	10,639
1500	1524	1940	2438	4072	2709	3350	16,724	10,639
1650	1676	2120	2438	4072	2709	3350	16,308	10,639
1800	1829	2320	2438	4072	2709	3350	15,832	10,639

Headwall 600 to 1800mm Pipe

Notes

1. Precast alternative to OPSD 804.040.
2. Designed in accordance with CSA S6 - CHBDC.
3. Headwall grates as shown are available upon request.
4. All dimensions are in millimeters unless otherwise shown.
5. Alternate openings are available upon request.

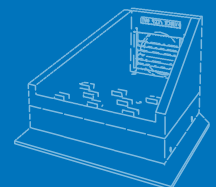

Rectangular Opening Alternative

Width	600-3700
Height	600-3700

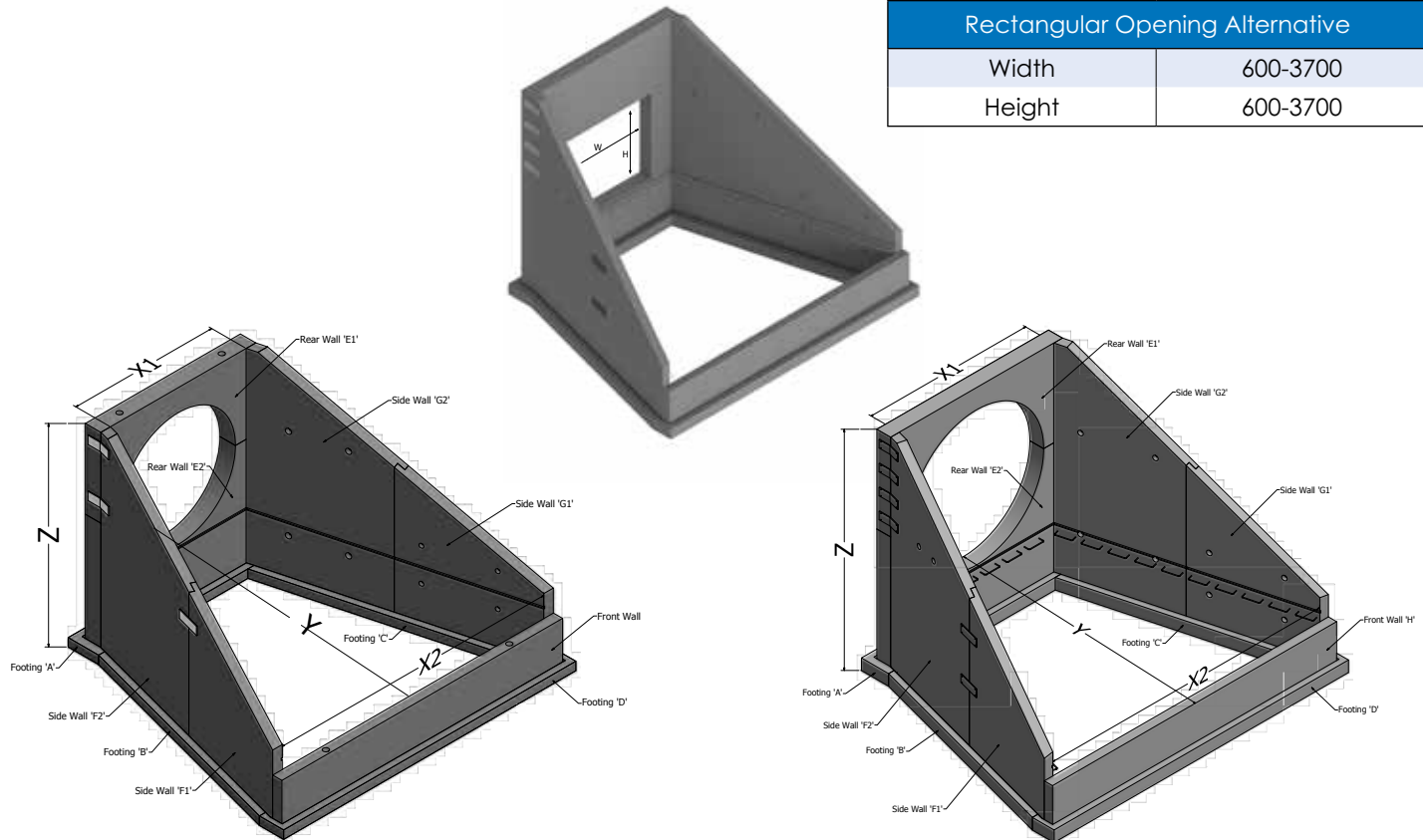

Pipe Size	Hole Diameter	Inside Width (Back)	Inside Width (Front)	Depth	Height (including footings)	Mass of Footings (by piece)			Mass of Back Wall (by piece)		Mass of Wing Walls (by piece)		Mass of Front Wall	Total Mass
Nom		X1	X2	Y	Z	A	B, C	D	E1	E2	F1, G1	F2, G2	H	KG
1950	2460	3353	6458	6404	4753	2373	2240	2835	5459	6757	3865	6647	3749	46677
2100	2640	3353	6458	6404	4753	2373	2240	2835	4790	6741	3865	6647	3749	45992
2250	2820	3353	6458	6404	4753	2373	2240	2835	4096	6702	3865	6647	3749	45259
2400	2990	4267	7372	6404	5743	2530	2305	3213	8999	9028	4333	7909	4244	57108
2550	3170	4267	7372	6404	5743	2530	2305	3213	8223	9020	4333	7909	4244	56324
2700	3360	4267	7372	6404	5743	2530	2305	3213	7332	8985	4333	7909	4244	55398
3000	3710	4267	7372	6404	5743	2530	2305	3213	5632	8868	4333	7909	4244	53581

Segmental Headwalls for 1950 to 3000mm Pipe

Notes

1. Floor and chute blocks are to be cast-in-place (by others).
2. Precast alternative to OPSD 804.040.
3. Designed in accordance with CSA S6-14 (CHBDC).
4. Headwall grates are available upon request.
5. All dimensions are in millimeters unless otherwise shown.
6. Alternate openings are available upon request.

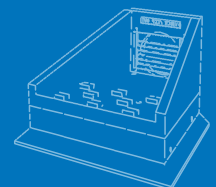

SECTION 8 TRENCH COVERS

M CON
PRODUCTS

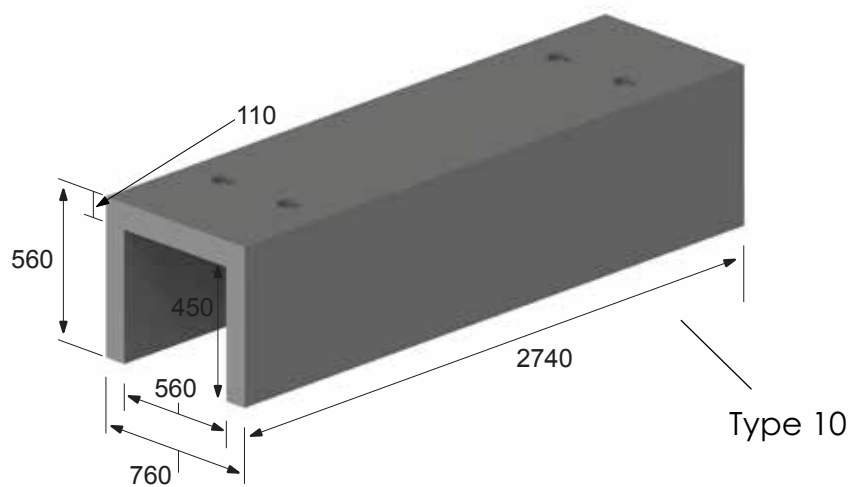
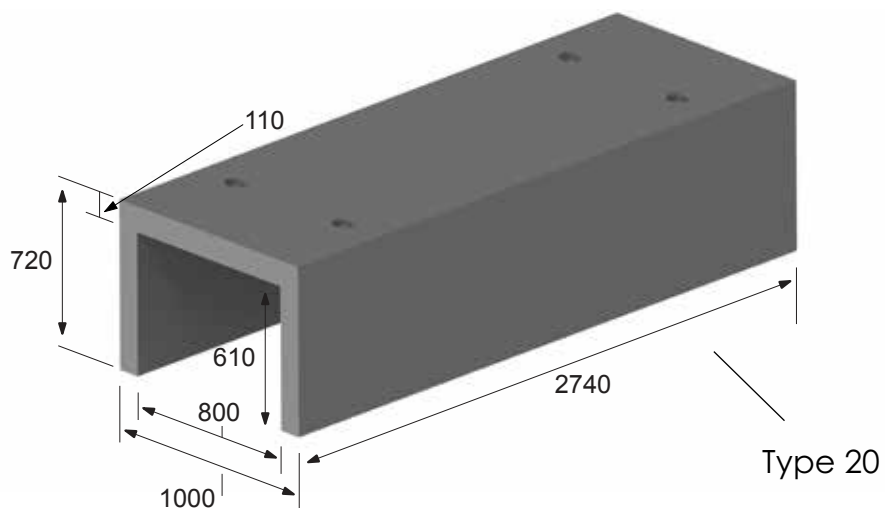

Trench Covers

Notes

1. Designed in accordance with CSA-S6-06.
2. Design Live Load: CL-625-ONT.
3. All dimensions are in millimetres unless otherwise shown.

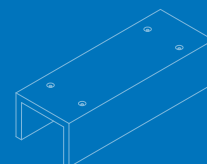

SECTION 9 STONE STRONG SYSTEMS®



M CON
PRODUCTS



M CON
PRODUCTS

M CON Products
2150 Richardson Side Road
Ottawa, ON, K0A 1L0, Canada
t. + 1 800 267 5515
e. sales@mconproducts.com



TABLE OF CONTENTS

SECTION 9 STONE STRONG SYSTEMS®

Stone Strong System	103
Stone Strong System Patterns	106
Stone Strong System Blocks	107
Inside Corner Block Outside Corner Block.	111



M CON Products
 2150 Richardson Side Road
 Ottawa, ON, K0A 1L0, Canada
 tf. + 1 800 267 5515
 e. sales@mconproducts.com

THE BIG EASY.

We're the first to agree: bigger is better. But we don't stop there. The biggest and most innovative precast block in the industry is also the easiest to work with. Stone Strong Systems' fully and intelligently engineered block technology allows for a lighter, interlocking block that greatly reduces installation time and labor costs — with unmatched safety, durability and aesthetics. It's big. It's easy. It's Stone Strong.



ROADWAY

Big-time projects demand big-time blocks – Stone Strong Systems' gravity walls are capable of heights in excess of 20 feet. Meanwhile, with proper engineering and reinforcement, Stone Strong MSE walls have topped nearly 50 feet.



COMMERCIAL

Big-time projects demand big-time blocks – Stone Strong Systems' gravity walls are capable of heights in excess of 20 feet. Meanwhile, with proper engineering and reinforcement, Stone Strong MSE walls have topped nearly 50 feet.



RESIDENTIAL

Make impossibly hard projects impossibly easy – Stone Strong Systems' tapered block edges provide the versatility needed to contour to any landscape, including straight, convex, concave and circular designs.

Stone Strong System

Notes

1. Contact the M CON engineering department for further information.

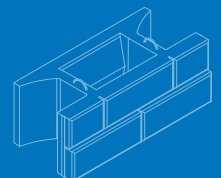

NOT JUST BIGGER. BETTER.

What is it that makes Stone Strong Systems the best block in precast? In a word — everything. Everyone knows we're the biggest block in the industry. But what they may not know is that we're the industry's most efficient retaining wall system as well. Or that our big block system is the first to be fully engineered both structurally and geotechnically. So no matter what you're looking for — size, speed or strength — Stone Strong Systems can meet your project requirements.



LIGHTER

Our system's unique hollow cavity means less weight per square foot, which translates into reduced transportation costs and a much faster, easier and less costly installation — install up to 1,200 square feet of block a day.



BIGGER

Huge 24-square-foot block dramatically reduces labor costs and installation time, while its sheer size and weight deliver structural strength without any need for tie-backs or additional mechanics.



INTERLOCKING

Lift/alignment loops ensure blocks interlock precisely and align units for consecutive level courses. Stone infill securely locks blocks together without any mechanical assistance.

Stone Strong System

Notes

1. Contact the M CON engineering department for further information.

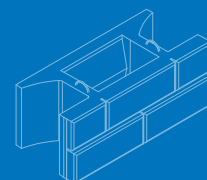



M CON
PRODUCTS

M CON Products

2150 Richardson Side Road
Ottawa, ON, K0A 1L0, Canada

tf. + 1 800 267 5515

e. sales@mconproducts.com

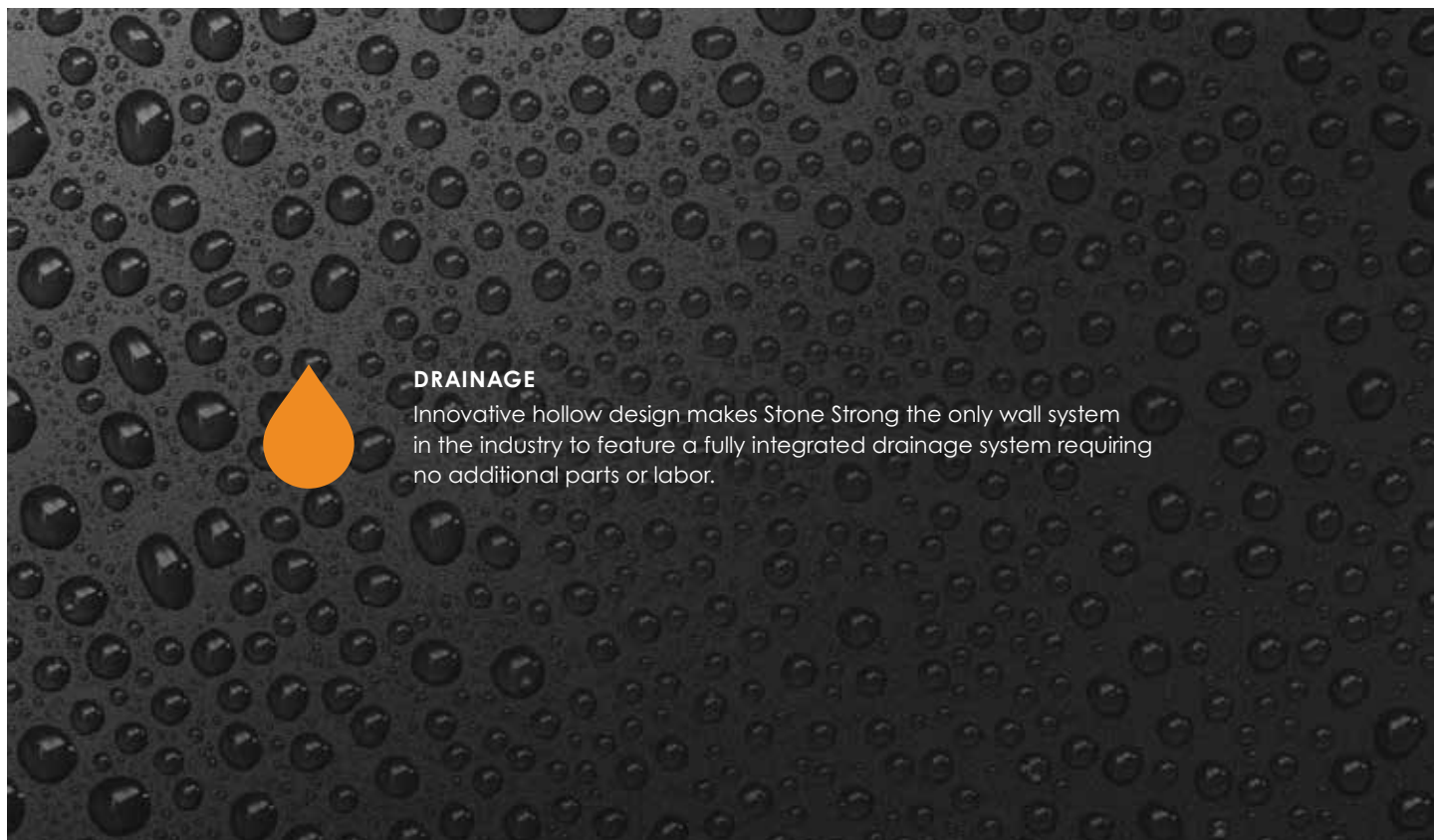

DRAINAGE

Innovative hollow design makes Stone Strong the only wall system in the industry to feature a fully integrated drainage system requiring no additional parts or labor.

THE BUILDING BLOCKS OF INNOVATION.

Comprised of more than a dozen fully engineered blocks, components and accessories, Stone Strong Systems combines the flexibility to accommodate any retaining wall project — large or small — with unmatched safety, durability and aesthetics. Every block is manufactured to product specifications to assure uniform weight, dimensional tolerance and strength, and unlike other brands, returned concrete is never used for Stone Strong blocks. Not to mention, every block is produced with air-entrained 4,000-psi concrete to protect it through even the most strenuous freeze/thaw cycles.

Stone Strong System

Notes

1. Contact the M CON engineering department for further information.

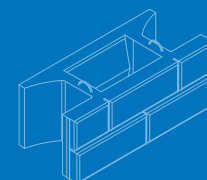

EVERY STONE STRONG BLOCK FEATURES A REALISTIC, CHISELED-STONE FAÇADE HANDCRAFTED BY REAL ARTISANS.

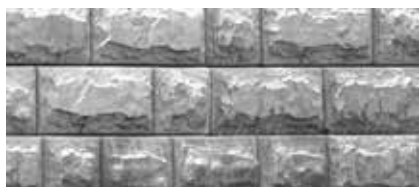

CHISELED GRANITE (Standard)

Derived from blocks hand-chiseled by artisans, the pattern is intended to match the classic look of natural, chiseled stone.



FRACTURED LEDGE (Special Order)

Created from actual fractured ledge stone, the highly defined pattern offers the most natural look.



POTOMAC (Special Order)

Smooth and broken up, this pattern was produced to replicate actual original cobblestone from the East Coast.



TENNESSEE FOOTHILLS (Special Order)

Sharp and well defined, the pattern was developed by laser-mapping actual retaining walls in the Smoky Mountains.



FLAT FACE (Special Order)

Stone Strong System Patterns

Notes

1. Contact the M CON engineering department for available patterns and colours.

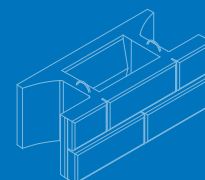



M CON

PRODUCTS

M CON Products

2150 Richardson Side Road
Ottawa, ON, K0A 1L0, Canada

tf. + 1 800 267 5515

e. sales@mconproducts.com



3-28 BLOCK

Face 2' X 18" x 28"

The 3 SF Block can be used on smaller walls where site depth is a factor. Weight 225 kilograms.



3-28 TOP BLOCK

Face 2' X 18" x 28"

The 3 SF Top Block can be used on smaller walls and easy to move around on-site with a skid loader or mini-excavator. Weight 200 kilograms.



3 SF BLOCK

Face 2' X 18" x 44"

The 3 SF Block allows the wall to stay on a running bond. This block is also available as a vertical. Weight 364 kilograms.



3 SF TOP BLOCK

Face 2' X 18" x 44"

Every Stone Strong block is manufactured to particular specifications to assure uniform weight, dimensional tolerance and strength. Weight 328 kilograms.



6-28 BLOCK

Face 4' X 18" X 28"

Stone Strong's tapered block edges provide the versatility needed to contour to any landscape. Weight 430 kilograms.



6-28 TOP BLOCK

Face 4' X 18" X 28"

Unlike other brands, returned concrete is never used for Stone Strong blocks. Weight 380 kilograms.



6 SF BLOCK

Face 4' X 18" X 44"

The 6 SF Block allows for tighter turning radii. This block is also available as a vertical. Weight 680 kilograms.



6 SF TOP BLOCK

Face 4' X 18" X 44"

Blocks interlock securely and precisely without any mechanical assistance. Weight 635 kilograms.



12 SF BLOCK

Face 8' X 18" X 44"

The 12 SF Block allows for quicker installation of 1.5 foot high courses. Weight 1360 kilograms.

Stone Strong System Blocks

Notes

1. Contact the M CON engineering department for further information.

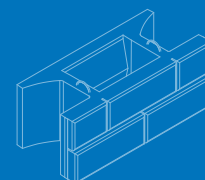



M CON PRODUCTS

M CON Products

2150 Richardson Side Road
Ottawa, ON, K0A 1L0, Canada
t. + 1 800 267 5515
e. sales@mconproducts.com



12 SF TOP BLOCK
Face 8' X 18" X 44"

Stone Strong's sheer mass holds the system together without the need for geogrid or soil reinforcement. Weight 1300 kilograms



24 SF BLOCK
Face 8' X 36" X 44"

This 24 SF Block is the Standard Stone Strong block. This block is also available as a vertical. Weight 2722 kilograms.



24 SF TOP BLOCK
Face 8' X 36" X 44"

The Top Block has an 8" recess at the top of the face to allow for multiple finish options. Weight 2449 kilograms.



24-62 BLOCK
Face 8' X 36" X 62"

The 24-62 Block builds walls up to 18' with no tie-back. This block is also available as a vertical. Weight 3109 kilograms.



24-86 BLOCK
Face 8' X 36" X 86"

The 24-86 Block builds walls up to 22.5' with no tie-back. This block is also available as a vertical. Weight 3489 kilograms.



24 SF MASS EXTENDER BLOCK
Face 8' X 36" X 56"

The addition of the extender to the 24 SF block provides for greater gravity wall heights. This block is also available as a vertical. Weight 4526 kilograms.



45 DEGREE BLOCK
Face 4' x 1.5' x 4'

The 45° Block provides for inside and outside 45° turns. Weight 910 kilograms.



45 DEGREE INSIDE CORNER TOP
Face 4' x 1.5' x 4'

The 45° Inside Corner Block provides for corners where the low grading is on the inside of the corner. Weight 757 kilograms.



45 DEGREE OUTSIDE CORNER TOP
Face 4' x 1.5' x 4'

The 45° Outside Corner Block provides for corners where the low grading is on the outside of the corner. Weight 837 kilograms.

Stone Strong System Blocks

Notes

1. Contact the M CON engineering department for further information.

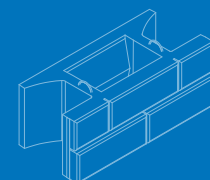



M CON

PRODUCTS

M CON Products
 2150 Richardson Side Road
 Ottawa, ON, K0A 1L0, Canada
 tf. + 1 800 267 5515
 e. sales@mconproducts.com



COLUMN 'T' BLOCK
Face 4' X 48" X 18"

90° Block with 1 finished side.
 Weight 1179 kilograms.



COLUMN 'T' TOP BLOCK
Face 4' X 48" X 18"

90° Top Block with 1 finished side.
 Weight 1179 kilograms..



90 DEGREE BLOCK
Face 48" X 48" X 18"

90° Block provides for inside and outside
 90° turns.
 Weight 1179 kilograms.



90 DEGREE CORNER TOP
Face 48" X 48" X 18"

90° Corner Top Block can be used for
 inside and outside 90° turns.
 Weight 1042 kilograms.



COLUMN END BLOCK
Face 48" X 48" X 48" X 18"

90° Block with 3 finished sides.
 Weight 1179 kilograms.



4' DUAL BLOCK
Face 4' X 18" X 28"

The 4' Dual Face Block provides for
 above-grade applications.
 Weight 800 kilograms.



8' DUAL BLOCK
Face 8' X 18" X 28"

The 8' Dual Face Block provides for
 above-grade applications.
 Weight 1597 kilograms.



END CORNER BLOCK
Face 4' X 18" X 24"

The End Corner block is used for 90° turns
 and for end finish treatments.
 Weight 640 kilograms.

Stone Strong System Blocks

Notes

1. Contact the M CON engineering department for further information.

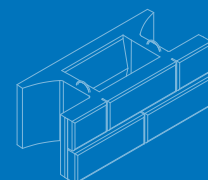



M CON

PRODUCTS

M CON Products
 2150 Richardson Side Road
 Ottawa, ON, K0A 1L0, Canada
 t. + 1 800 267 5515
 e. sales@mconproducts.com



45 DEGREE COLUMN CAP



90 DEGREE COLUMN CAP



4' END CAP



4' STEP CAP



8' STEP CAP



8' DUAL END CAP



8' END CAP

Column Cap Chart					
	End Finishing	Face Length	Height	Depth	Block Weight (kg)
4' End Cap Block	1 Finished End	4'	0.58	2.67'	405
4' Cap/Step Block	2 Flush Ends	4'	0.58	2.67'	405
8' End Cap Block	1 Finished End	8'	0.58	2.67'	726
8' Dual End Cap Block	2 Finished Ends	8'	0.58	2.67'	726
8' Cap/Step Block	2 Flush Ends	8'	0.58	2.67'	726
8' End Cap Block	1 Finished End	8'	0.58	2.67'	726

Stone Strong System Blocks

Notes

1. Caps with two flush ends can also be used for stairs and step applications.
2. Clamp required for installation.
3. Contact the M CON engineering department for further information.

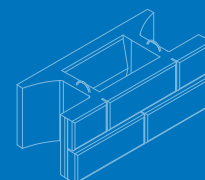



90 DEGREE INSIDE CORNER UNIT #1

Block Number	Length	A	B	C	Block Weight
1	65 in 1646 mm	25 in 641 mm	25 in 633 mm	19 in 485 mm	2070 lbs 940 kg
2	70 in 1790 mm	31 in 784 mm	31 in 777 mm	23 in 593 mm	2350 lbs 1065 kg
3	76 in 1934 mm	37 in 928 mm	36 in 921 mm	27 in 694 mm	2630 lbs 1195 kg
4	82 in 2077 mm	42 in 1072 mm	42 in 1064 mm	31 in 796 mm	2900 lbs 1315 kg
5	87 in 2221 mm	48 in 1215 mm	48 in 1208 mm	35 in 896 mm	3180 lbs 1445 kg
6	93 in 2365 mm	54 in 1359 mm	53 in 1352 mm	39 in 997 mm	3460 lbs 1570 kg



90 DEGREE OUTSIDE CORNER UNIT #1

Block Number	Length	A	B	C	Block Weight
1	65 in 1652 mm	42 in 1054 mm	48 in 1221 mm	44 in 1124 mm	2600 lbs 1180 kg
2	59 in 1508 mm	36 in 910 mm	42 in 1077 mm	40 in 1022 mm	2330 lbs 1055 kg
3	56 in 1415 mm	30 in 767 mm	37 in 933 mm	36 in 920 mm	2050 lbs 930 kg
4	48 in 1221 mm	25 in 623 mm	31 in 790 mm	32 in 819 mm	1770 lbs 805 kg
5	42 in 1077 mm	19 in 479 mm	25 in 646 mm	28 in 717 mm	1500 lbs 680 kg
6	37 in 933 mm	13 in 336 mm	20 in 502 mm	24 in 616 mm	1220 lbs 555 kg

Inside Corner Block
 Outside Corner Block

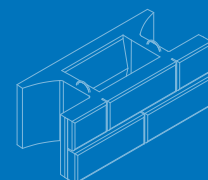

SECTION 10 ACCESSORIES

M CON
PRODUCTS

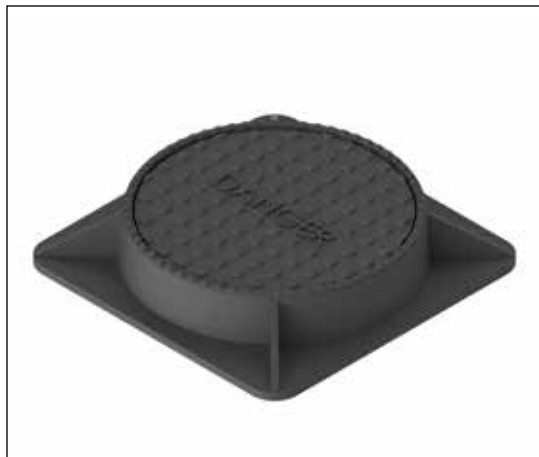

TABLE OF CONTENTS

SECTION 10 ACCESSORIES

OPSD Catch Basin Frame and Covers	114
OPSD Maintenance Hole Frame and Covers	116
City of Ottawa Frame and Covers	117
City of Ottawa Frame and Covers OPSD	118
Ditch Inlet Grate	119
Maintenance Hole Adjustment Rings	120
Catch Basin Adjustment Units	121
Adjustment Units	122
Maintenance Hole Aluminum Safety Platform and Steps	123
Pipe to Maintenance Hole Connector	124
Boot Gasket	125
Sealants for Box Structures	126
Swift Lifts and Boot Gasket	128
Pipe Gasket	129
Pipe to Maintenance Hole Connector	130



M CON Products
2150 Richardson Side Road
Ottawa, ON, K0A 1L0, Canada
t. + 1 800 267 5515
e. sales@mconproducts.com

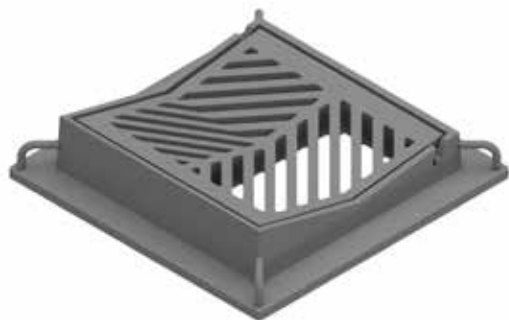

Maintenance Hole Frame & Cover
OPSD 400.40 - Type V



Catch Basin Frame & Cover
OPSD 400.07



Catch Basin Frame & Cover
OPSD 400.01 Dished Grate



Catch Basin Frame & Cover
OPSD 400.02 Flat Grate

OPSD Catch Basin
Frame and Covers

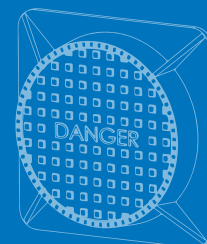



M CON Products
2150 Richardson Side Road
Ottawa, ON, K0A 1L0, Canada
t. + 1 800 267 5515
e. sales@mconproducts.com



Valve Chamber Frame and Cover
OPSD 402.01

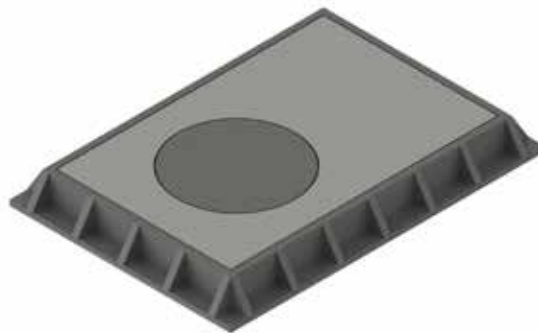

Meter/Valve Chamber
Frame and Cover
OPSD 402.03

OPSD Catch Basin
Frame and Covers

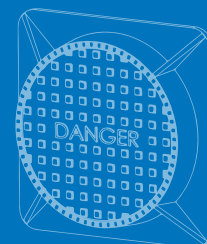



M CON Products
2150 Richardson Side Road
Ottawa, ON, K0A 1L0, Canada
t. + 1 800 267 5515
e. sales@mconproducts.com



Maintenance Hole Frame & Cover
OPSD 401.010 - Type A & B



Maintenance Hole Frame and Cover
OPSD 401.030



Maintenance Hole Frame and Cover
OPSD 401.020

OPSD Maintenance
Hole Frame and Covers

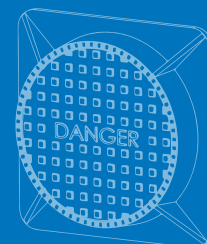



Valve Chamber / Maintenance Hole
 City of Ottawa Frame & Cover -
 W15/W16

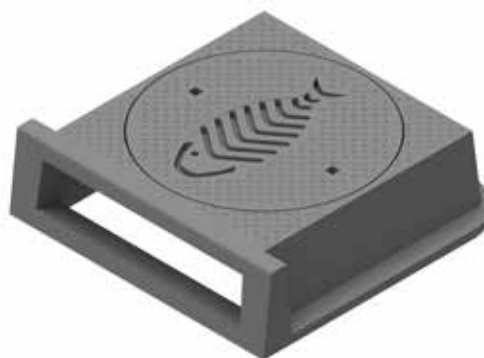

Curb inlet Catch Basin
 City of Ottawa Frame & Cover -
 S22/S23



Rear Yard Catch Basin
 City of Ottawa Frame and Cover

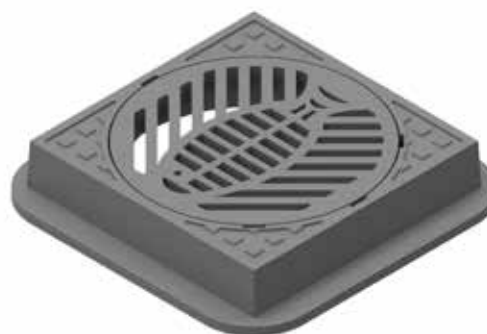

Catch Basin
 City of Ottawa Frame
 and Cover - S19

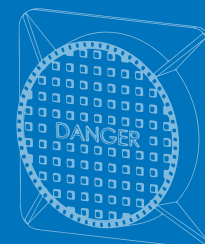



M CON Products
2150 Richardson Side Road
Ottawa, ON, K0A 1L0, Canada
t. + 1 800 267 5515
e. sales@mconproducts.com



Sanitary
City of Ottawa Frame & Cover -
S24/S25



Storm
City of Ottawa Frame & Cover
S24.1/S25



Open Grate
City of Ottawa Frame & Cover
S28.1

City of Ottawa
Frame and Covers
OPSD

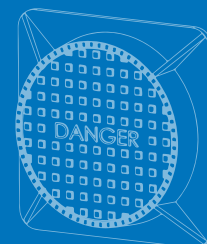



Ditch Inlet Grate - Type A



Ditch Inlet Grate - Type B



Ditch Inlet Grate - Type C

Grating Type	Grating Size	
	Length L	Width W
A	762	768
B	1338	768
C	1465	768

Ditch Inlet Grate

Notes

1. Conforms to OPSD 403.010
2. Type "A" grates are used on 600 x 600mm ditch inlets. See page 90.
3. Type "B" grates are used on 600 x 1200mm ditch inlets. See page 91.

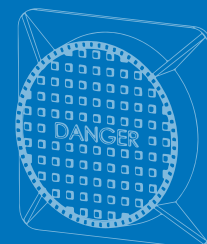

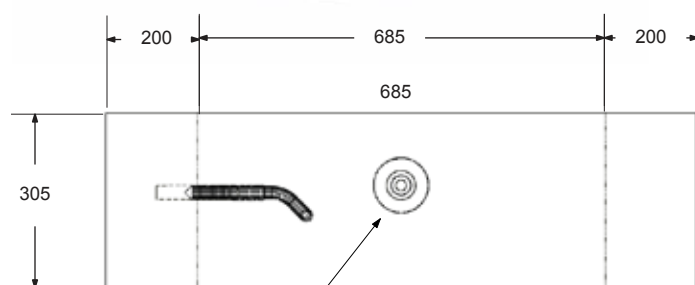
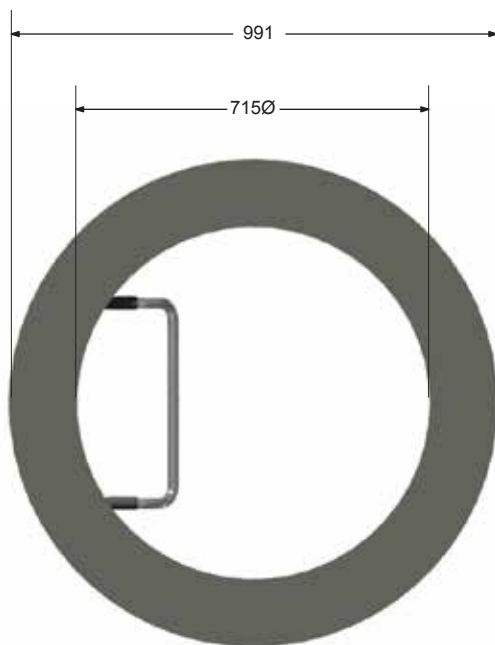

Lift Anchor

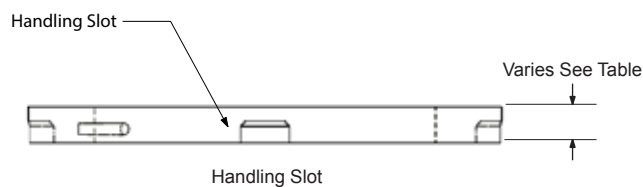

Unit Height	Bundle (PCS)	Mass (KG/EA)	Steps Y/N
50mm	10	55	N
75mm	8	82	N
100mm	6	109	N
150mm	6	164	N
300mm	1	325	Y

Maintenance Hole Adjustment Rings

Notes

1. Designed in accordance with OPSD 704.010.
2. All dimensions are in millimeters unless otherwise shown.

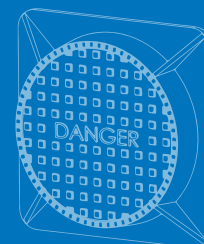

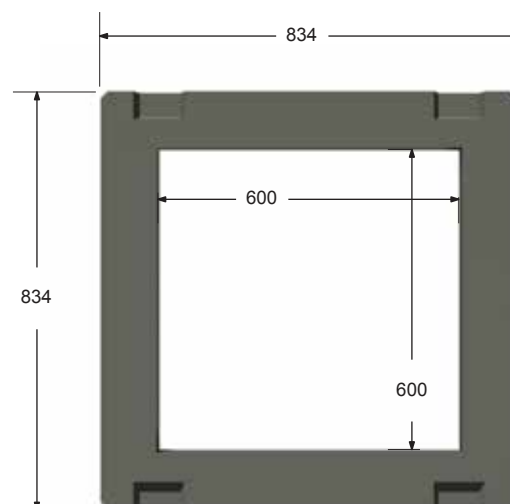
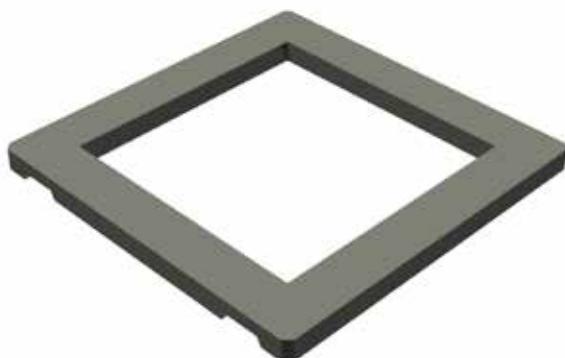

Unit Height	Bundle (PCS)	Mass (KG/EA)	Steps Y/N
50mm	10	40	N
75mm	9	61	N
100mm	6	84	N
150mm	4	121	N

Catch Basin Adjustment Units

Notes

1. Designed in accordance with OPSD 704.010.
2. All dimensions are in millimeters unless otherwise shown.

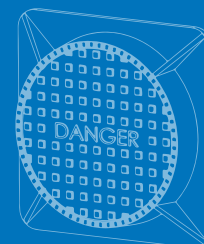



M CON Products
2150 Richardson Side Road
Ottawa, ON, K0A 1L0, Canada
t. + 1 800 267 5515
e. sales@mconproducts.com

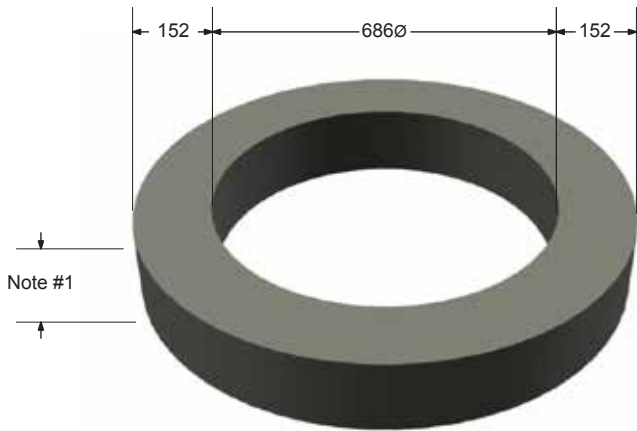

Maintenance Hole Adjuster

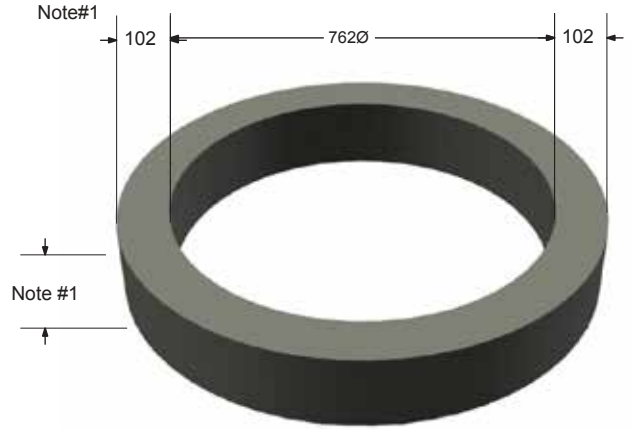

Valve Chamber Adjuster

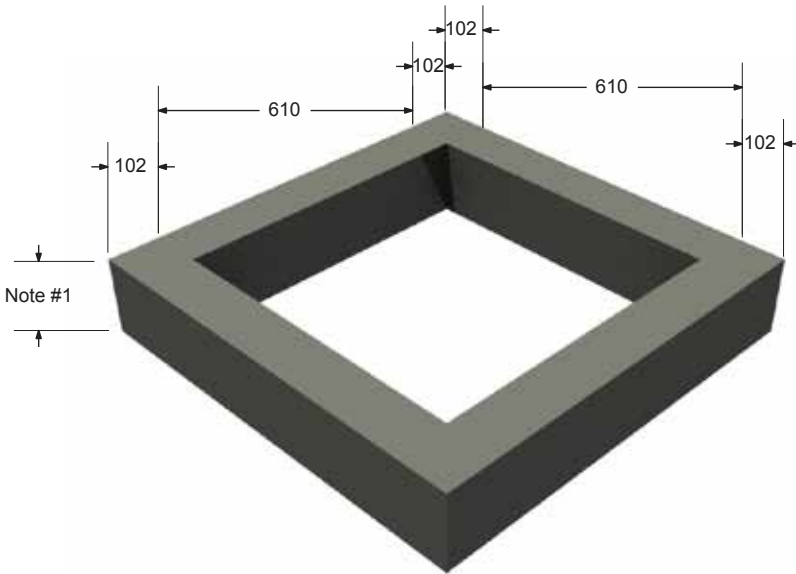

Catch Basin Adjuster

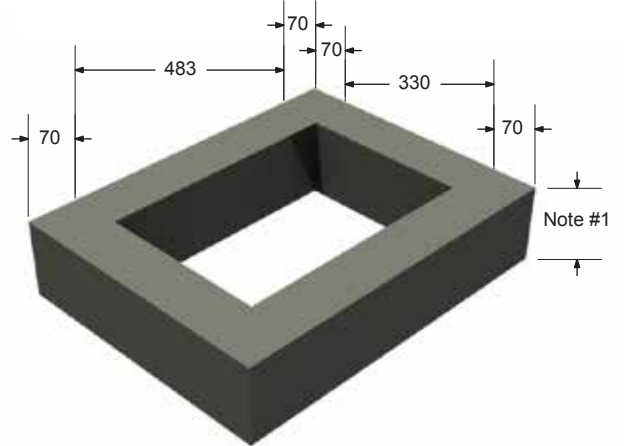

Rear Yard Catch Basin Adjuster

Adjustment Units

Notes

- 1. Heights as follows: 50mm, 75mm, 100mm, & 150mm.
- 2. Designed in accordance with OPSD 704.010.
- 3. All dimensions are in millimeters unless otherwise shown.

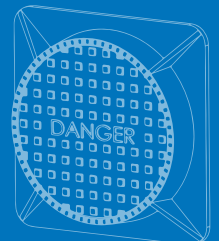



Aluminum Safety Platform



20mm Hollow Aluminum



20mm Solid Aluminum

Maintenance Hole Aluminum Safety Platform and Steps

Notes

1. Safety platforms designed in accordance with OPSD 404.020.
2. Steps designed as per OPSD 405.010 - Hollow - Standard. Steps as per OPSD 405.020 - Solid - available when specified.
3. All dimensions are in millimeters unless otherwise shown.

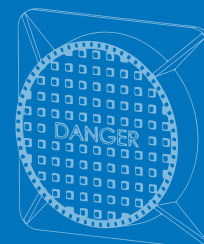



The rubber boot type connector is a common method of connecting both concrete and other pipe materials to maintenance holes, providing both a flexible and watertight connection. The boot connector ranges in sizes to suit the pipe outside diameter and also the maintenance hole diameter that the pipe is to be installed into.

Contact the M CON engineering department for further details on this connector or other connecting systems that are available.

Pipe Installation Procedure:

1. Clean pipe and boot to ensure no dirt or foreign materials are present.
2. Clamping surface on pipe must be clean and smooth.
3. Center pipe in opening and insert pipe until it breaks the inside plane of maintenance hole or, if maintenance hole is benched, to the invert ledge of benching.
4. Attach take-up clamp(s) and stagger screw(s) of clamps around the groove of the gasket so that take-up pressure will be equalized. Make sure each clamps is completely in the correct groove.
5. Using a torque ratchet or torque wrench, gradually tighten screw(s) of clamp(s) in an alternating pattern to 12 ft-lbs (for 8"-14" holes), 20 ft-lbs (for 16"-20" holes), or 60 ft-lbs (for 22" holes and larger).
6. After reaching the recommended torque from Note 5 on the final screw, check all screws again to ensure compression of the clamps.
7. Adjust pipe to line and grade.

Pipe to Maintenance
Hole Connector

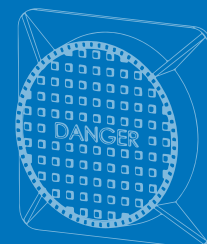

Pipe Size (and class)	Hole Size	Preferred Boot (all from Press Seal)	Alternative (from Trellborg)	Notes
50 PVC	203mm (8")	8 QRS PSX:DD (Step)	none	
75 PVC	203mm (8")	8 QRS PSX:DD (Step)	none	
100 PVC	203mm (8")	8 QRS PSX:DD (Step)	none	
125 PVC (DR 28-35)	203mm (8")	08-11 PSX:DD	"10-06 PSX:DD from Press Seal"	10-06 alternative needs a 10" hole. NOTE: PSX 08-05:DD are obsolete and not interchangeable with 08-11's.
150 PVC (DR 14-35)	305mm (12")	12-06 PSX:DD	S106-12BWS	
200 PVC (DR 28-35)	305mm (12")	12-08 PSX:DD	106-12AWS	
200 PVC (DR 14-35)		12M PSX:DD	S106-12WS	
250 PVC (DR 14-35)	356mm (14")	14M PSX:DD	S106-14AWS	
300 PVC (DR 14-25)	406mm (16")	16M PSX:DD	S106-16WS	
300 PVC (DR 28-35)				
350 PVC (DR 18-25)	508mm (20")	20Y PSX:DD	S106-20BWS	
375 PVC (DR 28-35)	508mm (20")	20Y PSX:DD	S106-20BWS	
450 PVC (DR 18-25)	610mm (24")	24L PSX:DD	S206-24A	
450 PVC (DR 28-35)	559mm (22")	22M PSX:DD	S206-24A	NOTE: S206-24A alternative needs a 24" hole.
500 PVC (DR 18-25)	660mm (26")	26L PSX-2:DD	S206-24L	NOTE: S206-24L alternative needs a 24" hole.
525 PVC (DR 28-35)	660mm (26")	26L PSX-2:DD	S206-26	
600 PVC (DR 18-25)	762mm (30")	30L PSX-2:DD	S206-30	
600 PVC (DR 28-35)	711mm (28")	28A PSX-2:DD	S206-28	
300 RCP	559mm (22")	22L PSX-2:DD	S206-20L	
375 RCP	610mm (24")	24A PSX-2:DD	S206-24L	
450 RCP	711mm (28")	28A PSX-2:DD	S206-28	
525 RCP	813mm (32")	32L PSX-2:DD	S206-32	Both boots require an 1500mm MH minimum. S306-32 option will work in a 1200mm MH.
600 RCP	914mm (36")	36A PSX-2:DD (needs 1800mm MH)	S206-34L (needs 1500mm MH)	NOTE: S206-34L alternative needs a 34" hole S306-34L option will work in a 1200mm MH.
675 RCP	1016mm (40")	40L PSX-2:DD (needs 1800mm MH)	S206-38L (needs 1800mm MH)	NOTE: S206-38L alternative needs a 38" hole S306-38L option will work in a 1500mm MH.
750 RCP	1067mm (42")	42A PSX-2:DD	S206-42	Both boots require an 1800mm MH minimum.

Boot Gasket

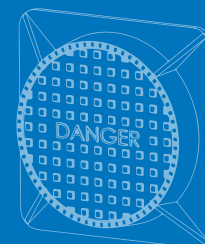

M CON

PRODUCTS

M CON Products
 2150 Richardson Side Road
 Ottawa, ON, K0A 1L0, Canada
 tf. + 1 800 267 5515
 e. sales@mconproducts.com



Butyl Tape
 (Box Manhole Sealant)



Hydrophilic Waterstop
 (Betonite Waterstop Material)



Paraseal® Paraprimer™
 (Paraseal Accessory Primer)



Mel-Rol Waterproofing Membrane
 (Self-Adhering Sheet Waterproofing)

Sealants for Box
 Structures

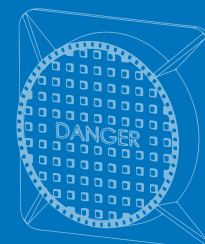



M CON
PRODUCTS

M CON Products

2150 Richardson Side Road
Ottawa, ON, K0A 1L0, Canada

tf. + 1 800 267 5515

e. sales@mconproducts.com



Mel-Prime Primer
(Solvent-Based VOC Adhesive)



King Redi-Plug Hydraulic Cement
(For sealing active water leaks in
concrete)

Sealants for Box
Structures

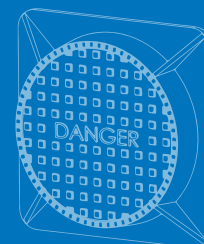



M CON
PRODUCTS

M CON Products
2150 Richardson Side Road
Ottawa, ON, K0A 1L0, Canada
t. + 1 800 267 5515
e. sales@mconproducts.com

Swift Lift 4T



Swift Lift 8T



Swift Lift 20T



Swift Lift Universal Lifting Eye Dimensions								
Rated Load Tons	A	B	C	D	Ex2	F Maximum Width	G Minimum Thickness	H
4	4.6"	2.8"	3.5"	11.0"	3.46"	1.02"	0.31"	2.26"
8	6.3"	3.3"	4.4"	15.6"	4.40"	1.31"	0.47"	2.90"
20	7.3"	4.6"	5.9"	20.4"	5.98"	1.86"	0.71"	4.35"

Swift Lifts and Boot Gasket

Notes

- Contact our engineering department for special design applications.

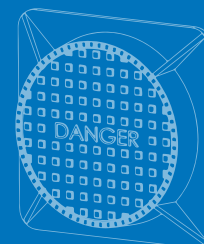



in	Feet Per Roll	Rolls Per Box	Feet Per Box
Kent Seal #2, Butyl Sealant - Oil Resistant (Nitrile)			
3/4	14'6"	8	116
Kent Seal #2, Butyl Sealant			
1/2	21'9"	12	261
3/4	14'6"	8	116
1	14'6"	6	87
1 1/4	14'6"	4	58

Pipe Size		TSS Style	Cut Length Inches
in	mm		
Tylox SuperSeal Pipe Gaskets			
12	300	135	42-1/8
15	375	135	52
18	450	135	60-1/2
18	450	135	62-3/8
21	525	135	69-1/8
24	600	135	77-5/8
27	675	135	86-1/4
30	750	135	95-5/8
33	825	135	104-1/4
36	900	135	112-3/4
39	975	135	121-3/8
42	1050	185	126-1/8
48	1200	185	142-1/2
54	1350	185	158-5/8
60	1500	185	176
66	1650	185	193-5/8
72	1800	185	210-7/8
78	1950	225	228-3/8
84	2100	225	246-1/8
90	2250	225	264
96	2400	225	281-3/4
102	2550	225	299-1/2
108	2700	225	318 3/4

Pipe Gasket

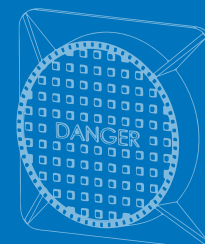

Pipe Size		TSS Style	Cut Length Inches
in	mm		
Tylox SuperSeal Maintenance Gaskets			
48	1200	166	147-1/2
60	1500	165	181-1/2
72	1800	165	220-1/2
NITRILE Gaskets			
12	300	135	42-1/8
15	375	135	52
18	450	135	60-1/2
18	450	135	62-3/8
21	525	135	69-1/8
24	600	135	77-5/8
27	675	135	86-1/4
30	750	135	95-5/8
33	825	135	104-1/4
36	900	135	112-3/4
39	975	135	121-3/8
42	1050	185	126-1/8
48	1200	185	142-1/2
54	1350	185	158-5/8
60	1500	185	176
66	1650	185	193-5/8
72	1800	185	210-7/8
78	1950	225	228-3/8
84	2100	225	246-1/8
90	2250	225	264
96	2400	225	281-3/4
120	3000	225	349-1/4

Pipe Size		TSS Style	Cut Length Inches
in	mm		
Tylox SuperSeal Maintenance NITRILE Gaskets			
48	1200	165	147-1/2
60	1500	165	181-1/2
72	1800	165	220-1/2
FT-III Connector Series (NITRILE)			
6	150	SDR35	21-1/2
8	200	SDR35	28-1/8
10	250	SDR35	34-3/4
12	300	SDR35	41-1/8
15	375	SDR35	49-7/8
Three Step cored hole gaskets			
4	100	1576	14-1/4
5	125	1576	18-5/8
6	150	1576	20-3/8
8	200	1576	26-3/4
10	250	1576	34-1/8
12	300	1576	40-1/8
FT-III Connector Series			
1" x 3/8" Recess Former Strip, 60 Durometer, Neoprene 1-1/2" x 1/2" Neoprene 60 Durometer 0.656 x 0.25 Nitrile Material (21/32" O.D. x 1/4" I.D.) 0.656 x 0.25 Neoprene Material 45 Durometer (21/32" x 1/4" I.D.)			
6	150	SDR35	21-1/2
8	200	SDR35	28-1/8
10	250	SDR35	34-3/4
12	300	SDR35	41-1/8
15	375	SDR35	49-7/8

Pipe to Maintenance
Hole Connector

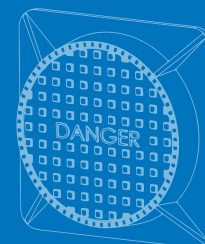

M CON PRODUCTS

M CON Products
2150 Richardson Side Road
Ottawa, ON, K0A 1L0, Canada
t. + 1 800 267 5515
e. sales@mconproducts.com

Stormwater Management: Echelon Systems



Retaining Wall Blocks: Stone Strong Systems



M CON IS PART OF THE PRECAST GROUP. COLLECTIVELY, WE ARE THE MOST DIVERSE SUPPLIER OF PRECAST PRODUCTS IN ONTARIO. IF OTHER PRECAST PRODUCTS ARE REQUIRED, PLEASE DO NOT HESITATE TO CONTACT ONE OF OUR AFFILIATED COMPANIES.



25 Bongard Avenue
Ottawa, ON, K2E 6V2, Canada
t. +1 613 225-9510 ff. +1 800 267-3487
www.centralprecast.com
info@centralprecast.com

PRODUCT LINE

Landscape Products	Distributors of interlocking stones, retaining walls, slabs and curbing
Architectural Precast	Manufacturers of architectural precast for buildings such as big box stores and condo buildings
Masonry Furnishings	Manufacturers of masonry furnishings that include sills, lintels, coping and caps
Site Furnishings	Manufacturers of planters, steps, garbage receptacles, benches, ashtrays, etc.
Fencing	Manufacturers of various precast concrete fencing systems
Columns & Signs	Manufacturers of custom columns and signs to your specifications
Shelters	Manufacturers of a variety of standard shelters



61 Bongard Avenue
Ottawa, ON, K2E 6V2, Canada
t. +1 613 225-6398 ff. +1 800 267-5515
www.utilitystructures.com
info@utilitystructures.com

PRODUCT LINE

Concrete Poles	Manufacturers of concrete poles for hydro distribution, street lighting
Utility Structures	Manufacturers of utility vaults, distribution chambers, and other electrical structures
Highway Barriers	Manufacturers of standard OPSD concrete barriers
Specialty Items	Bollards, Aluminum Pole bases